

# AUTOMOTIVE



- The contents of this catalogue are effective as of October 2025.
- Certain products listed in this catalogue may not be available in some countries. Please contact us via our website for product availability.
- The information contained in this catalogue is subject to change without prior notice. This can be for, but not limited to, product improvement or other reasons at our own discretion.
- The data and figures contained in this material are NOT guaranteed values but typical values.
- The application examples of products stated in this catalogue are for illustrative purposes only and NOT guaranteed. Please read all instructions completely before use.
- All text and images in this catalogue are copyrights of Nitto Denko Corporation.
- All logos, product names, and other related information used in this catalogue are the brands or registered trademarks of Nitto Denko Corporation and its affiliates in Japan and/or other countries.
- If you wish to use the content of this catalogue for purposes other than the original intent, please consult us in advance. Any unauthorized use, copying or reprinting of the contents or part thereof in this catalogue without obtaining our prior written consent is strictly prohibited.
- For detailed product information or inquiries, please contact us via our website.  
<https://www.nitto.com/jp/en/products/>



## Nitto Denko Corporation

26th Fl., Shinagawa Season Terrace, 1-2-70, Konan, Minato-ku, Tokyo 108-0075, Japan

TEL: +81-3-6632-2101 FAX: +81-3-6632-2025 <https://www.nitto.com/jp/en/>

CATALOG CODE: 20012 Issued in October 2025

0210F10 ©  
2310R07 ©  
2510R

# CONTENTS

PAGE	No.	PRODUCT NAME	PAGE	No.	PRODUCT NAME	PAGE	No.	PRODUCT NAME	PAGE	No.	PRODUCT NAME	PAGE	No.	PRODUCT NAME	
04		Nitto Transportation Technical Center (NTTC)													
<b>NVH, Waterproofing and Sealing Products</b>			<b>Products for Bonding and Jointing</b>			<b>Products for Surface Protective Materials</b>			<b>Environment-friendly Products</b>			<b>Automobile Electronic Products</b>			
05	01	NITTO EPTSEALER™ Sealing Material	11	07	HJ-9150W Transparent tape	15	15	Polyolefin (PO) SPV™ Overview	18	19	SCF™ Super Clean Foam	23	24	NITOFLO™ No. 903UL Fluoroplastic Adhesive Tape	
06		How to Select NITTO EPTSEALER™		08	No. 5015 Multipurpose Double-coated Adhesive Tape					19	20	No. 512 Low VOC Double-coated Adhesive Tape		25	NITOFLO™ No. 973UL-S Fluoroplastic Resin Impregnated Glass Cloth Adhesive Tape
07	02	No. 6800 Series NITTO EPTSEALER™	12	09	No. 500 Multipurpose Double-coated Adhesive for General Purposes	<b>Products for Harness</b>			20	21	No. 5000NS Removable Tape	24	26	No.188UL Glass-cloth Adhesive Tape	
	03	No. 685 Series NITTO EPTSEALER™		10	TW-Y01 Double-coated Adhesive Tape for Plastics and Foams	16	16	No.156A Low-VOC PVC Tape/Heat and flame resistant, high heat resistant, thick type PVC adhesive tape	21	22	OW-5016 Double-coated Adhesive Tape for Oily Surface		27	No. 360 Series Polyimide Adhesive Tape	
08	04	EE-1000 Series NITTO EPTSEALER™	13	11	HF-105S For Fixing Roof Wire Harness to Module Unit	17	17	No. 5/No. 5EG/No. 153/No. 153N/No.156A Acetate Cloth Adhesive Tape Series	22	23	EW-514/EW-514D/EW-514DB Low-VOC Double-coated Adhesive Tape	25	28	TEMISH™ High Performance Vent Filter	
	05	EC-100 Series Flame-retardant NITTO EPTSEALER™		12	HF-105E Low-VOC for Fixing Roof Wire Harness to Module Unit							29	29	HT Sheet Thermal Conductive Sheet	
09	06	EH-2200 Series Sulfur Less NITTO EPTSEALER™	14	13	VR-5311/VR-5321 For Vulcanized Rubber Applications							30	30	ELEP COAT LSS Series Heat-resistant Moisture Proof Coating Material for PCB	
		Application Examples for NITTO EPTSEALER™		14	VR-5000/VR-5300/VR-5300H Strong-adhesion and Repulsion Resistance Double-coated Adhesive Tape								31	NPN Insulating Paper	

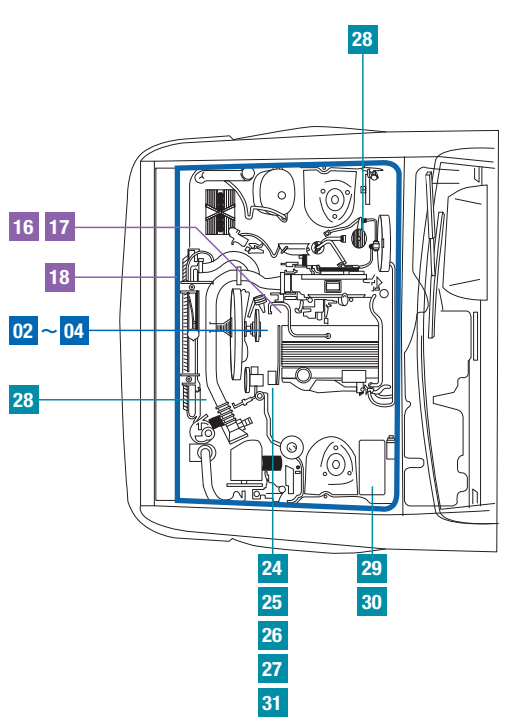
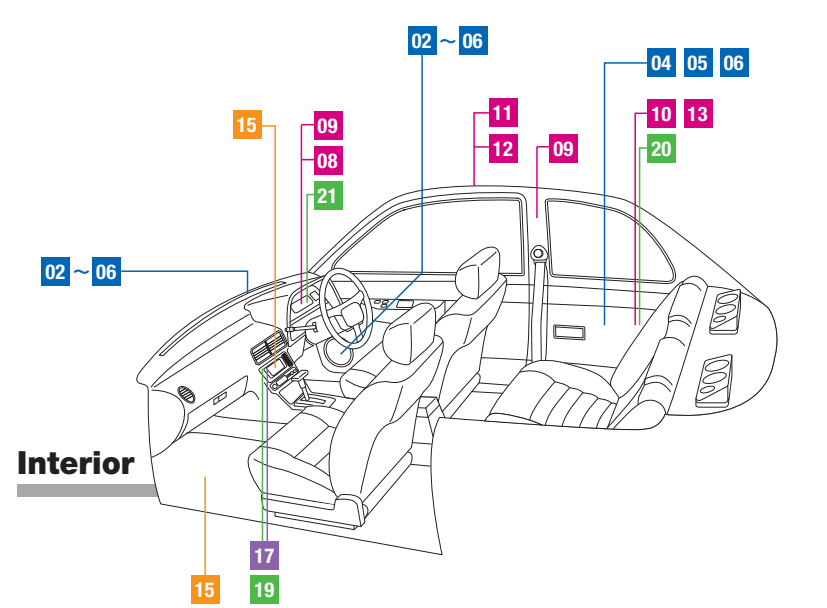
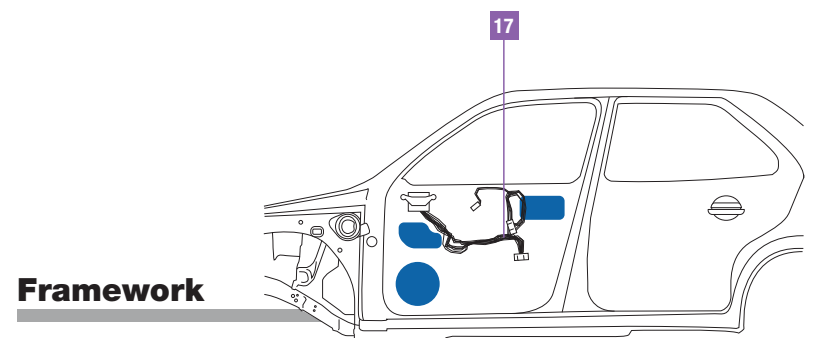
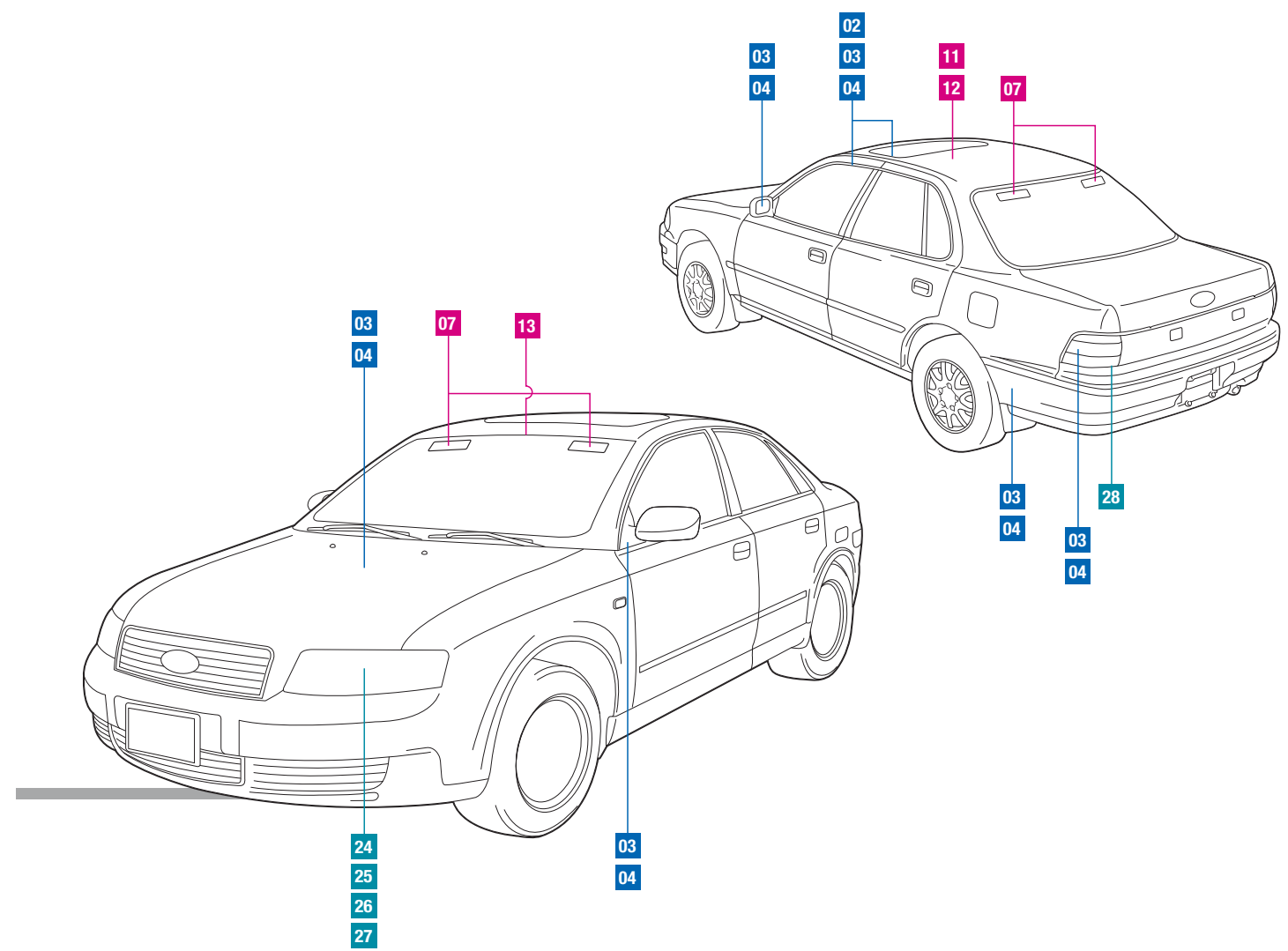



## Provision of products and solutions for automobiles and all other sorts of transportation equipment

These days, the meaning of the term “mobility” is undergoing great change.

In this age, we at Nitto provide products and solutions for automobiles and all other sorts of transportation equipment taking

“the environment,” “safety,” “comfort,” and “design” as our key words.

How would you go about joining two things with completely different qualities and forms?

They cannot be linked merely by putting them together.

Between any two things, there is bound to be a gap, however small.

The things to be linked may be iron and plastic, gas and air, or people and objects.

Nevertheless, whatever the gap, it is our job at Nitto to stand in the middle to fill it and generate new value and functions adapted to customer wants and needs.

We are firmly committed to continued contribution to value creation by customers in Green, Clean, and Fine areas, through full application of leading-edge technologies based on polymer synthesis technology.

## Nitto Transportation Technical Center (NTTC)

We have established five NTTCs worldwide (Japan, North America, Europe, China and Thailand), providing total solutions to all our customers.

### NTTC's Function and Mission

#### When problems occur with the vibration of outer panels

- To find vibrating sources and understand the vibration state
- To propose products to be selected, locations to be applied and their sizes, etc.

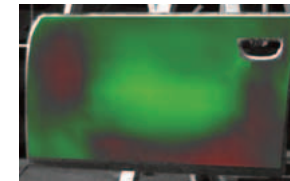

#### When problems occur with the evaluation of actual items

- To evaluate actual items such as panels based on full scale models
- To reproduce actual heating conditions and propose handling and construction methods

\*Some tests may be difficult to perform under actual conditions.



#### When problems occur with the rigidity of outer panels

- To quantitatively evaluate the current situation
- To examine many different shapes and materials and propose the best conditions

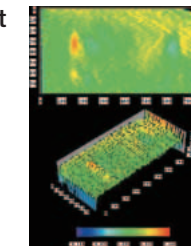

#### When problems occur with practical evaluation

- To propose additional evaluation results
- To make evaluations and proposals depending on actual usage conditions

### Establishment of five NTTCs worldwide (Japan, North America, Europe, China and Thailand)

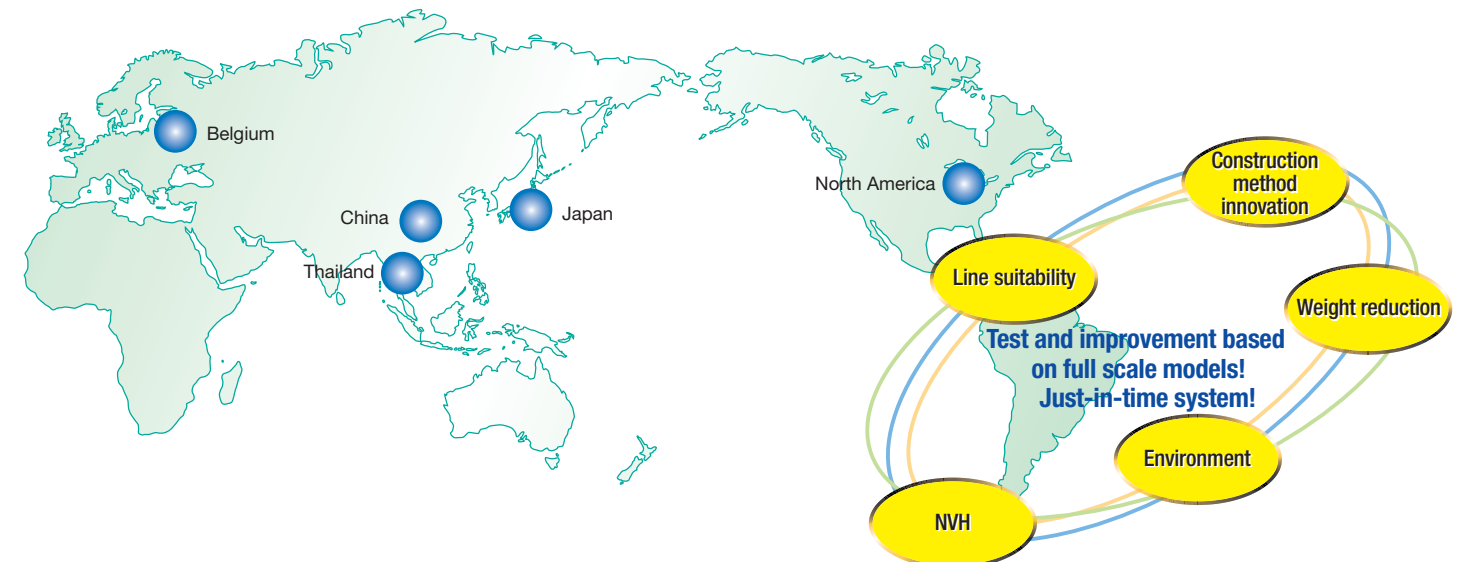

# Sealing Material NITTO EPTSEALER™



**NITTO EPTSEALER™ contributes to enhancing the reliability of products with superior properties.**

NITTO EPTSEALER fills various types of gaps, whether the purpose is to shut out heat, water, sound or vibration, and serves well as a sealing material. Highly functional sealing properties have been developed by blending EPDM rubber foam, which offers the best durability and weather-resistance among general rubber materials, as well as Nitto's unique adhesive technology. Superior resistance to heat and chemicals allows stable and consistent performance over a long period of time. Since NITTO EPTSEALER is manufactured in four main regions, speedy delivery and stable supply are available worldwide.

### Features

- The main constituent is EPDM rubber foam.
- Offers superior durability and resistance to high and low temperatures, weather and chemicals (acids and alkali)\*. \*Compared with general purpose rubber
- Using excellent foam processing technology, Nitto provides foam materials with low density and flexibility.
- Closed and semi-closed cell structures are available, which is only possible with Nitto's foam processing technology.

### Structure

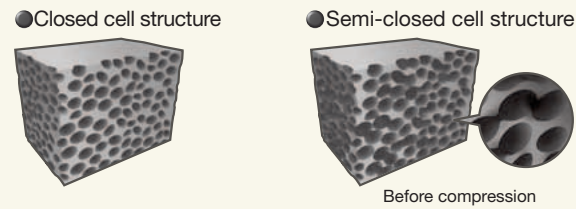

### Properties

--- No. 6800    — No. 685    ..... EE-1000

#### Compression Ratio

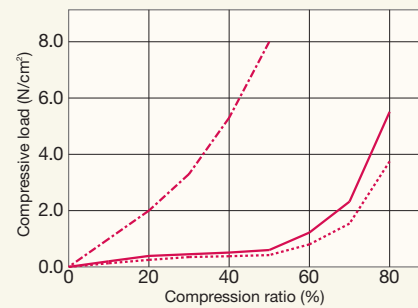

Note: Compression speed: 10mm/min.  
 Compression ratio (%) =  $\frac{100 \times (\text{Pre-compression thickness} - \text{Post-compression thickness})}{\text{Pre-compression thickness}}$   
 Each 10cm x 10cm test specimen was compressed at the rate of 10mm/min. until the preset thickness was reached. The compressive load was then measured after a 10 second delay.

#### Heat Resistance

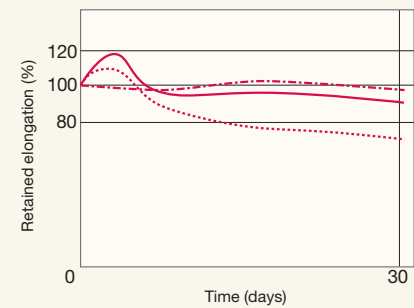

Note: Test specimens prepared using a #1 dumbbell die were exposed to each temperature condition. At the end of each time interval, the test specimens were stretched at the rate of 500mm/min., and the maximum elongation before rupture was measured. Retained elongation was calculated as a percentage of the new specimen's elongation. Measurement temperature: 80°C

#### Weather Resistance

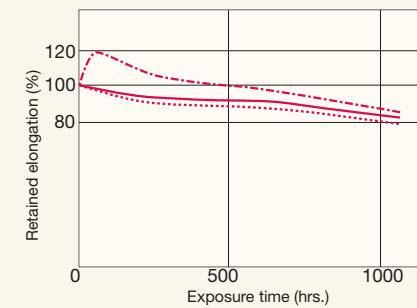

Note: Each test specimen was placed in a sunshine carbon weather meter and taken out after a set time to measure the elongation by stretching at the rate of 500mm/min. Retained elongation was calculated as a percentage of the new specimen's elongation.

#### Watertightness

○ No water leakage after 30 min.    △ Water leakage within 30 min.    × Water leakage within 10 min.

Item	Watertightness		
	No. 6800	No. 685	EE-1000
Compression ratio (%)			
50	○	×	×
60	○	△	×
70	○	○	△
80	○	○	○

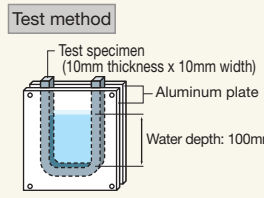

Note: U-shaped 10mm wide test specimens were punched out and placed between acrylic and aluminum plates for compression to a preset load. The test specimens were then filled with water to the depth of 100mm and checked for leakage.

#### Chemical Resistance

Chemicals	Item	Tensile Strength (N/cm²)		
		No. 6800	No. 685	EE-1000
Initial		35.3	10.8	8.8
Acid (1% H <sub>2</sub> SO <sub>4</sub> )		30.4	10.3	7.9
Alkali (1% NaOH)		36.3	9.8	7.5

Note: 20°C × 168 hrs. immersion

#### Comparison of Weather Resistance

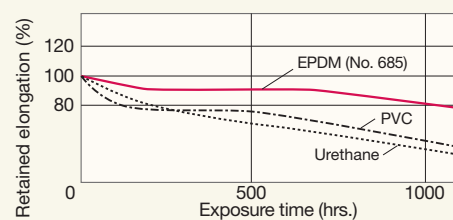

Note: Each test specimen was placed in a sunshine carbon weather meter and taken out after a set time to measure the elongation by stretching at the rate of 500mm/min. Retained elongation was calculated as a percentage of the new specimen's elongation.

#### Good Balance of General Properties

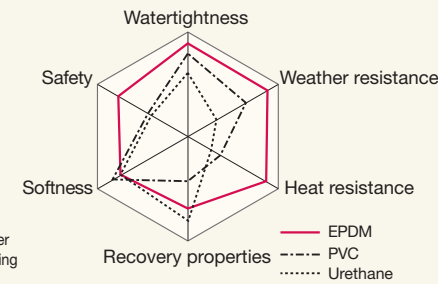

## How to Select NITTO EPTSEALER™

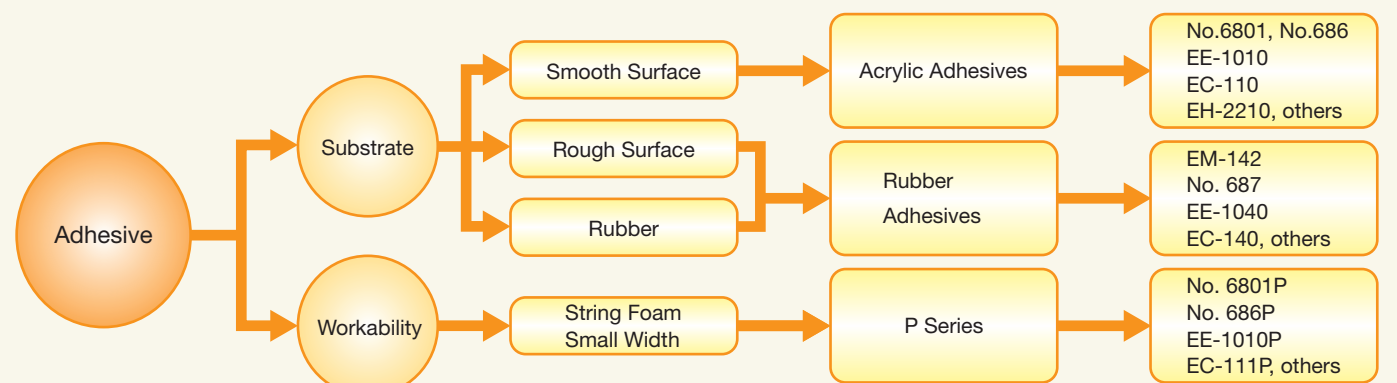
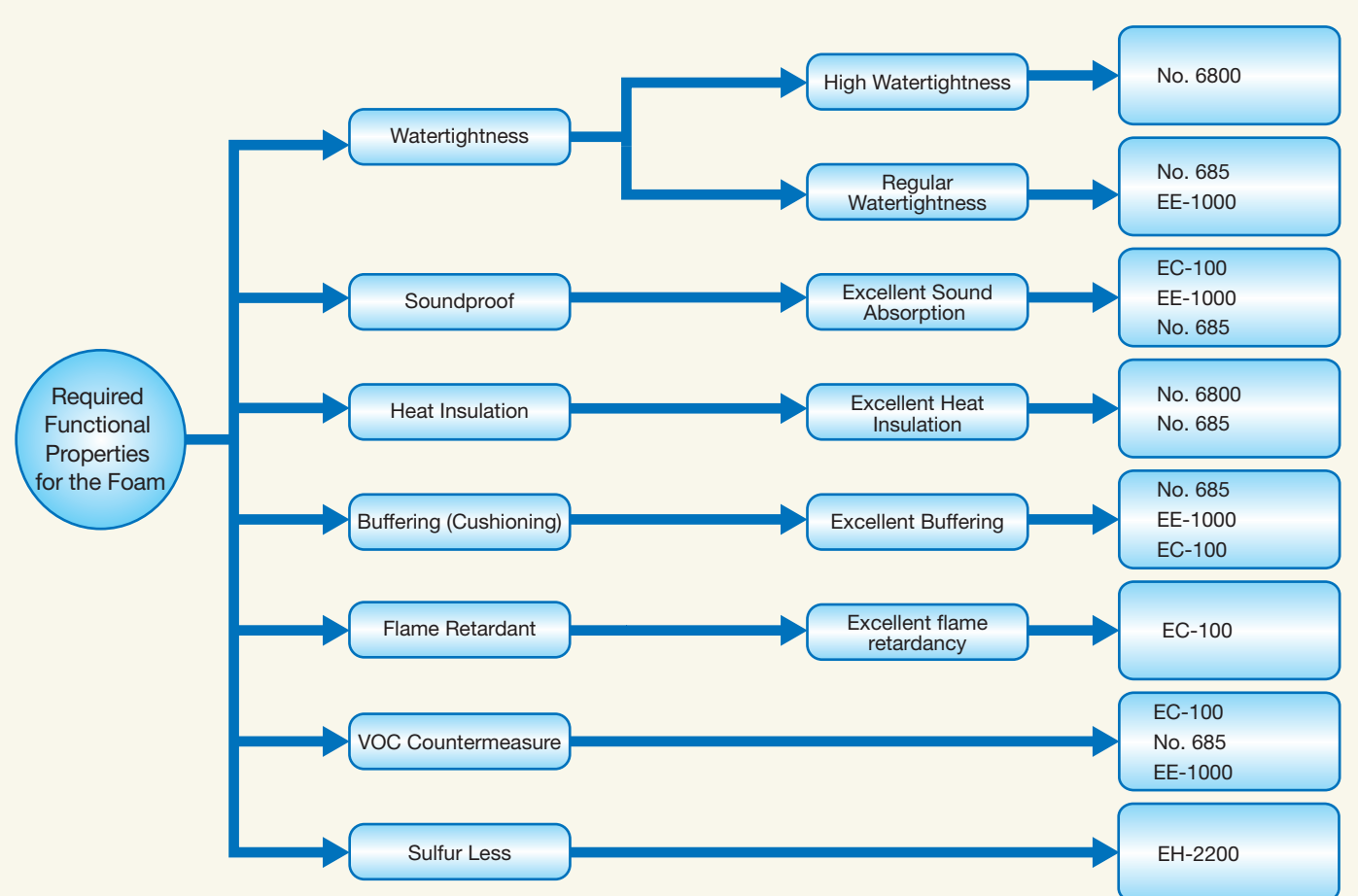

\* The measurements for the above foams and adhesives are approximate measures. Please contact us for specific details.  
 \* Foam layer is certified as flame-retardant

## 02 NITTO EPTSEALER™ No. 6800 Series

Closed cell structure

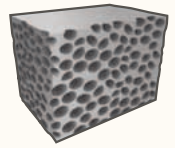

### Closed cell structure foam: sealing material with flexibility, elasticity, weather resistance and watertightness

The No. 6800 Series is a high-function foam sealing material consisting of EPDM rubber foam with a closed cell structure, which offers the best durability and weather resistance among general purpose rubbers. The No. 6800 Series offers variations in adhesive tapes, in which you can select between rubber adhesive or acrylic adhesive to best suit your needs.

#### Features

- Superior weather resistance and watertightness. Offers better heat resistance than foam water sealers such as urethane and polyethylene.
- No. 681 and No. 6801 are coated with an acrylic adhesive and offer superior holding power, heat resistance and weather resistance.
- Closed cell structure offers flexibility and elasticity.
- Can be easily installed in clearances with complicated shapes.

#### Applications

- Sealing of air conditioner frames
- For objects/areas requiring superior watertightness
- For mounting sunroof

#### Structure

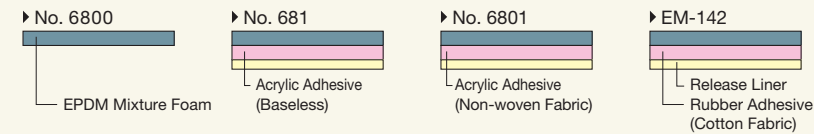

#### Standard Size

Thickness (mm)	Width (mm)	Length (m)
2-15 (with adhesive: 2-15)	1,000	2

#### Properties

Product No.	Density (g/cm <sup>3</sup> )	Tensile Strength (N/cm <sup>2</sup> )	Elongation (%)	Conforms to JIS K 6767 Compression Hardness (N/cm <sup>2</sup> )	
				25%	50%
No. 6800 Series	0.11	35	240	2.5	8.0

## 04 NITTO EPTSEALER™ EE-1000 Series

Semi-closed cell structure

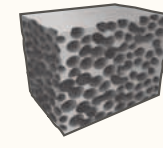

### Foam sealing material with superior resistance to cold, heat and chemicals with high weatherability

The EE-1000 Series is a foam sealing material, which consists of EPDM synthetic rubber foam with a semi-closed cell structure for filling the gaps, which are found in various types of equipment. The EE-1000 Series features high-quality foam with a higher degree of foam expansion. Given the specific compression rate for the intended application, the EE-1000 Series is suitable for waterproofing, windproofing, dustproofing, soundproofing and thermal insulation use.

#### Features

- Low VOC foam as sealing material.
- Offers superior durability and resistance to weather, cold and heat (-20 to 100°C), and chemicals (acids and alkalis).
- Compression load (stress) is slight, so structure is not deformed after mounting objects with foam sealer.
- Flexible material is easy to use when compressed.
- Low apparent density of 0.11; foam pieces do not fuse together.

#### Applications

- Waterproofing, air sealing, soundproofing and thermal insulation for air conditioners and air cleaners
- Mounting of cowl louvers, door mirrors and center pillar garnish

#### Structure

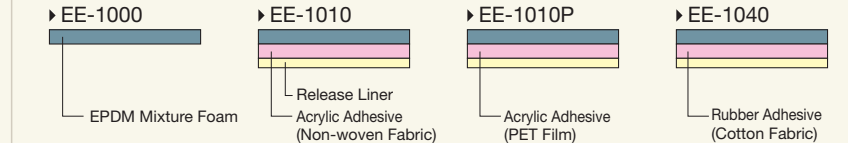

#### Standard Size

Thickness (mm)	Width (mm)	Length (m)
5-25 (with adhesive: 3-25)	1,000	2

#### Properties

Product No.	Density (g/cm <sup>3</sup> )	Tensile Strength (N/cm <sup>2</sup> )	Elongation (%)	Conforms to JIS K 6767 Compression Hardness (N/cm <sup>2</sup> )	
				25%	50%
EE-1000 Series	0.11	8.0	450	0.33	0.45

## 03 NITTO EPTSEALER™ No. 685 Series

Semi-closed cell structure

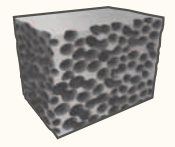

### Semi-closed cell structure foam: sealing material with flexibility, elasticity, weather resistance and watertightness

The No. 685 Series is a high-function foam sealing material, which consists of EPDM rubber foam with a semi-closed cell structure. EPDM rubber offers the best durability and weather resistance as rubber used for general purposes. Made of a flexible material, the No. 685 Series is easy to compress, and thus offers superior watertightness and airtightness. The series offers a selection of various adhesive tape materials from rubber to acrylic to meet customers' needs.

#### Features

- Low VOC foam as sealing material.
- Offers superior durability and resistance to weather, cold and heat (-20 to 100°C), and chemicals (acids and alkalis).
- Compression load (stress) is slight, so structure is not deformed after foam filling.
- Flexible material is easy to use when compressed.
- Low apparent density of 0.13; foam pieces do not fuse together.

\*VOC (Volatile Organic Compounds)

#### Applications

- Sealing of air conditioner ducts
- For objects/areas requiring superior watertightness
- For instrumental panel and front windshield mounting
- For mounting of door mirrors and center pillar

#### Structure

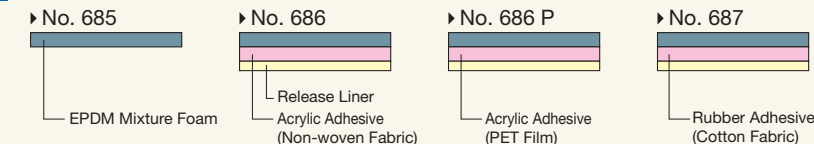

#### Standard Size

Thickness (mm)	Width (mm)	Length (m)
5-35 (with adhesive: 3-40)	1,000	2

#### Properties

Product No.	Density (g/cm <sup>3</sup> )	Tensile Strength (N/cm <sup>2</sup> )	Elongation (%)	Conforms to JIS K 6767 Compression Hardness (N/cm <sup>2</sup> )	
				25%	50%
No. 685 Series	0.13	10	550	0.39	0.60

## 05 Flame-retardant NITTO EPTSEALER™ EC-100 Series

Semi-closed cell structure

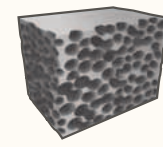

### EPDM foam sealing containing a flame retarder is UL94 HF-1 certified.

Products of the Nitto EC-100 Series which have obtained UL94 HF-1 certification are composed of a flexible foam sealing material consisting of EPDM rubber foam with a semi-closed cell structure mixed with a flame retarder. (Only foam (EC-100) has UL94 HF-1 certification, refer to UL official data sheet for certified thickness) Various types with adhesive layers are available, all of which take advantage of their flexible foam properties. The products can be used for waterproofing, airtightness, soundproofing, or thermal insulation according to the compression ratio.

#### Features

- Containing chlorine-free flame retarder, EC-100 series has obtained UL94 HF-1 certification, the most stringent standard for flame retardancy of foam. (Only foam (EC-100) has UL94 HF-1 certification. Refer to UL official data sheet for certified thickness)
- Minimal stress facilitates compression; fits snugly to uneven surfaces thereby enabling airtight sealing and soundproofing.
- Superior heat, weather, and ozone resistance enables the foam to withstand long-term use.

#### Applications

- Waterproofing, air sealing, soundproofing, and thermal insulation for electronics, OA equipment, and train.
- Sealing material for EV battery case

#### Structure

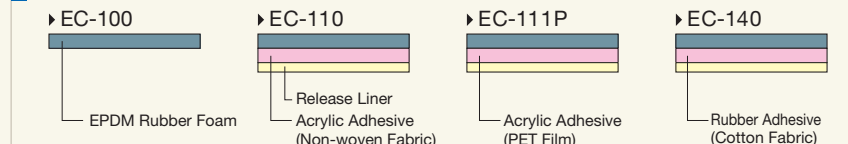

#### Standard Size

Thickness (mm)	Width (mm)	Length (m)
5-20 (with adhesive: 3-25)	1,000	2

#### Properties

Product No.	Density (g/cm <sup>3</sup> )	Tensile Strength (N/cm <sup>2</sup> )	Elongation (%)	Conforms to JIS K 6767 Compression Hardness (N/cm <sup>2</sup> )	
				25%	50%
EC-100 Series	0.085	7.0	270	0.18	0.28

### Sulfur Less NITTO EPTSEALER™ EH-2200 Series

Semi-closed cell structure

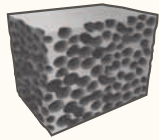

**EPDM foam sealing material that does not contain sulfur, which may cause metal corrosion**

This is a shaped sealing material made of EPDM rubber foamed into a semi-closed cell structure. It is a clean foam that contains no sulfur which is commonly used in rubber vulcanization and could corrode metals. It can be used for cushioning, soundproofing, and dustproofing applications without corroding metals in the vicinity of electronic equipment with high airtightness, which has recently become increasingly compact.

**Features**

- Since sulfur is not used, it excel in resistance to metal corrosion.
- Since compression load is low, it does not deform the structure after application.
- Be excellent at durability, weather-resistance, heat-resistance, and chemical resistance.
- Only foam (EH-2200) has UL94 HBF certification. Refer to UL official data sheet for certified thickness.

**Applications**

- Buffer, sound insulation, and dustproof material for electronic devices and electronic components.
- Seal material for around electronic circuit board.
- Seal material for around LED lightning.
- Seal material for around lithium-ion battery (LIB).

**Structure**

▶ EH-2200

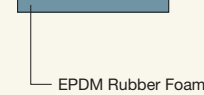

▶ EH-2210

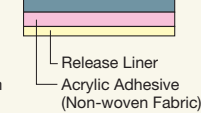

**Standard Size**

Thickness (mm)	Width (mm)	Length (m)
3-20 (with adhesive: 3-20)	900	2

**Properties**

Product No.	Density (g/cm <sup>3</sup> )	Tensile Strength (N/cm <sup>2</sup> )	Elongation (%)	Conforms to JIS K 6767	
				Compression Hardness (N/cm <sup>2</sup> )	50%
EH-2200 Series	0.11	6.0	270	0.22	1.30

### Application Examples for NITTO EPTSEALER™ (Exterior)

● **Mounting Cowl Louver** A-A'

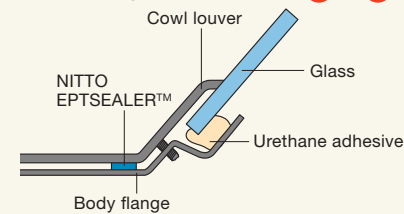

● **Mounting Ventilation Duct** C-C'

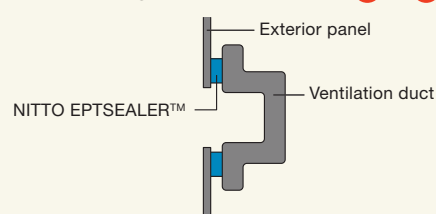

● **Mounting Center Pillar** D-D'

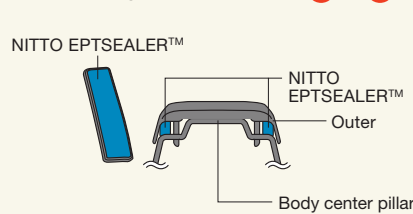

● **Mounting Sunroof** B-B'

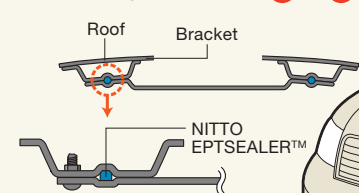

● **Mounting Door Mirror** E-E'

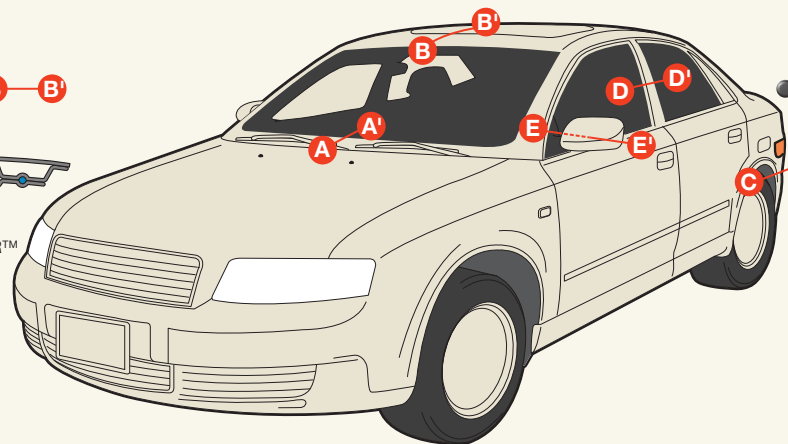
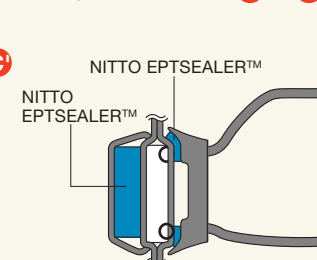

### Application Examples for NITTO EPTSEALER™ (Interior)

● **Mounting Door Mirrors**

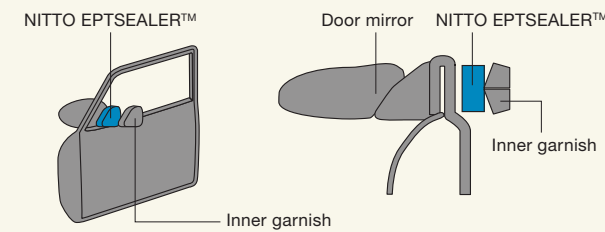

● **Instrument Panel**

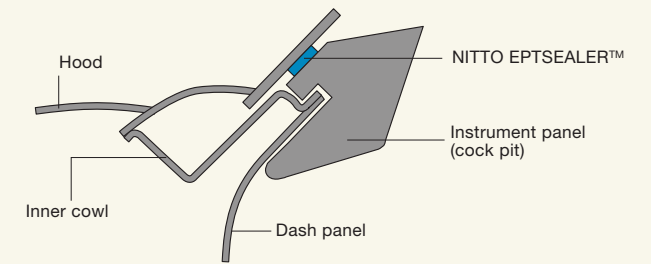

● **Built-in Door Speaker**

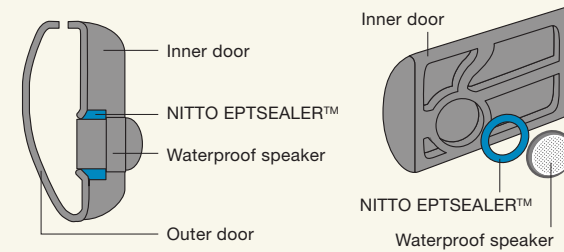

● **Inner Door**

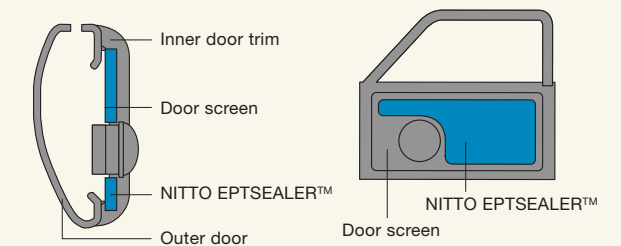

07

Transparent Tape HJ-9150W



Non-carrier double-coated adhesive tape with excellent transparency

HJ-9150W is a non-carrier double-coated adhesive tape that is clean and transparent. The tape has a strong adhesion with ultra thin adhesive. Offers superior bonding for automotive diversity antennas.

Features

- Offers superior transparency.
- Appearance is not damaged, even when used in places exposed to sunlight or high temperatures/humidity.
- Ideal for application to plastics such as polycarbonate.
- Offers strong adhesion, easy processing, user friendliness and produces minimal volatile gas.

Structure

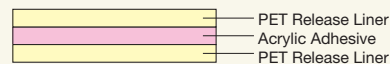

Applications

- Bonding of glass
- Application of optical film to display panel surfaces
- Film tape for automobile diversity antennas



Standard Size

Product No.	Tape Thickness (mm)	Width (mm)	Length (m)
HJ-9150W	0.05	20-500	50

Properties

180° Peeling Force

Substrate	180° Peeling Force (N/20mm)
Acrylic Plate	11.3
Glass Plate	9.8
Polycarbonate Plate	7.9
PET Plate	7.4
Stainless Steel Plate	10.8
Aluminum Plate	8.3

\*Measured by peeling in a 180° direction at a speed of 300mm/min at 23°C with polyester film 0.025mm lining.

Weather Resistance

Product No.	Aging Time
HJ-9150W	3000hrs.

○ Good appearance with no color change  
 Note: Tape is sandwiched between PET release liners and then placed in a sunshine carbon weather meter. The specimen is removed after the prescribed amount of time and then assessed by viewing the appearance.

Humidity and Heat Resistance

Product No.	Aging Time
HJ-9150W	1000hrs.

○ Good appearance with no color change  
 Note: Tape is applied to glass slides and then placed in an 80°C, 90% RH atmosphere. The specimen is removed after the prescribed amount of time and then assessed by viewing the appearance.

09

Multipurpose Double-coated Adhesive Tape for General Purposes No. 500



Popular general purpose double-coated adhesive tape

Nitto's most popular double-coated adhesive tape for multiple use consists of flexible nonwoven fabric impregnated with pressure-sensitive adhesive. Superior adhesive strength makes the tape ideal for general bonding.

Features

- Offers excellent adhesive strength for nameplates, metal plates, etc.
- Offers better repellency than other double-coated adhesive tapes and prevents separation from the substrate to which it is applied.
- Can be widely used as an industrial double-coated adhesive tape.
- Line-up includes No. 500AB with a black adhesive.

Structure

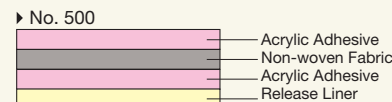

Standard Size

Carrier	Tape Thickness (mm)	Width (mm)	Length (m)
Non-woven Fabric	0.17	3-1,200	50

Applications

- Fixing of punched metal nameplates
- Fixing of garnish for automobile meter panels, air conditioners, etc.
- Fixing of ABS decorative panels
- Fixing of plastic display panels

Properties

180° Peeling Force (for each substrate)

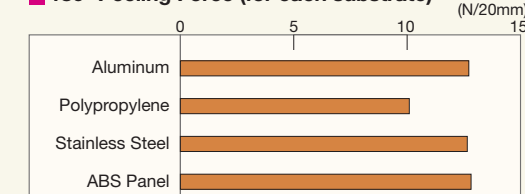

\*Measured by peeling in a 180° direction at a speed of 300mm/min at 23°C with polyester film 0.025mm lining.

08

Multipurpose Double-coated Adhesive Tape No. 5015

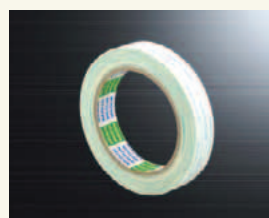

Strong double-coated adhesive tape for fixing interior materials and nameplates

No. 5015 consists of flexible nonwoven fabric, which is impregnated with powerful pressure-sensitive adhesive. Stable adhesive strength can be expected for metals and various types of plastics such as polyethylene and polypropylene. No. 5015 is able to provide stable fixing of nameplates and foam due to its good repellency that enables a small amount of force to be applied continuously.

Features

- Offers stable adhesive strength for various materials including metal and plastic.
- Offers superior adhesive strength for temperatures ranging from low to high.
- Maintains stable fixing even in environments where a small amount of force is constantly applied.

Structure

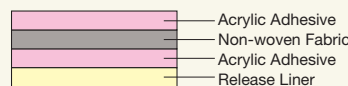

Standard Size

Carrier	Tape Thickness (mm)	Width (mm)	Length (m)
Non-woven Fabric	0.12	3-1,200	50

Applications

- Fixing of interior materials
- Fixing of various types of nameplates
- Fixing of car air conditioner insulation materials

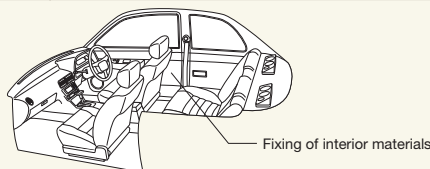

Properties

180° Peeling Force (for each substrate)

Substrate	Peeling Force (N/20mm)
Stainless steel	16.0
Aluminum	15.5
PP	12.5
PC	13.5
ABS	13.5
PVC	16.0
PSt	13.5
POM	10.0

180° Peeling Force (for each temperature)

Substrate	Temperature	Peeling Force (N/20mm)
Stainless steel	0°C	21.0
	23°C	16.0
	40°C	13.0
	60°C	12.0
	80°C	10.5

10

Double-coated Adhesive Tape for Plastics and Foams TW-Y01



Offers superior repellency, adheres well to rough surfaces such as foam.

TW-Y01 consists of flexible nonwoven fabric impregnated with pressure-sensitive adhesive. The tape can be easily applied to plastics such as polypropylene and the rough surfaces of foams.

Features

- Easily applied to rough surfaces such as foam and plastic materials such as polypropylene.
- Excellent repellency

Structure

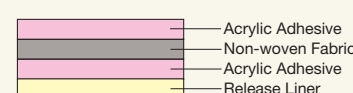

Standard Size

Carrier	Tape Thickness (mm)	Width (mm)	Length (m)
Non-woven Fabric	0.17	3-1,200	50

Properties

Product No.	180° Peeling Force (N/20mm) (For stainless steel)
TW-Y01	15.2

\*Measured by peeling in a 180° direction at a speed of 300mm/min at 23°C with polyester film 0.025mm lining.

Applications

- For bonding plastics and foams

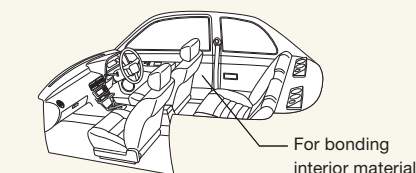

## 11 For Fixing Roof Wire Harness to Module Unit HF-105S

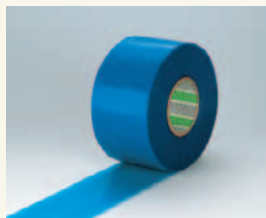

**HF-105S adheres firmly to the roof head lining and other rough surfaces. This single-coated tape offers superior initial and low-temperature adhesiveness.**  
 HF-105S also adheres firmly to rough surfaces, offering superior initial adhesion at low temperatures. This tape offers good workability as an adhesive tape for automobile roof applications.

### Features

- HF-105S is a single-coated adhesive tape, and the base is polyolefin film. HF-105S is designed for partial bonding of roof modules.

### Structure

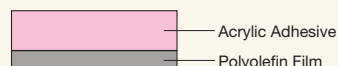

### Applications

- Fixing of roof wire harness to module unit

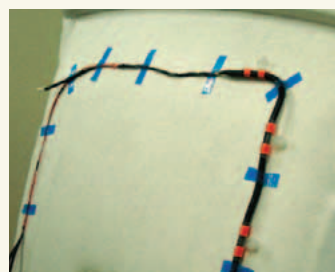

### Standard Size

Carrier	Tape Thickness (mm)
Polyolefin film	0.23

## 12 Low-VOC for Fixing Roof Wire Harness to Module Unit HF-105E



**HF-105E adheres firmly to the roof head lining and other rough surfaces. This single-coated tape offers superior initial and low-temperature adhesiveness.**  
 HF-105E also adheres firmly to rough surfaces, offering superior initial adhesion at low temperatures. This tape offers good workability as an adhesive tape for automobile roof applications. Awarded the 46th "Environmental Award" in Japan.

### Features

- Excellent adhesion to rough surface (foam, non-woven fabric, felt).
- By using a flexible PP carrier, it has good followability and is also hand-cut.
- Use no organic solvents (toluene, xylene, ethyl acetate, etc.)
- The guideline values for the 13 VOCs specified by Japan's Ministry of Health, Labour and Welfare are satisfied.

### Structure

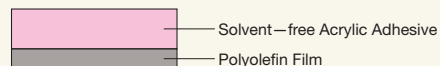

### Applications

- Fixing of roof wire harness to module unit
- Good workability due to hand cutting

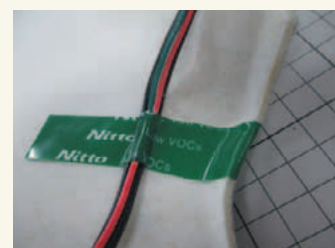

### Standard Size

Carrier	Tape Thickness (mm)
Polyolefin film	0.14

## 13 For Vulcanized Rubber Applications VR-5311 (Strong Holding Power)/ VR-5321 (Strong Initial Adhesion)

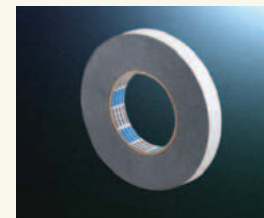

**Excellent adhesion for bonding vulcanized rubber sheets. Adheres well without a primer**

Nitto's double-coated adhesive tape consists of a PET film carrier with rubber adhesive on one side and acrylic adhesive on the other side. Ideal for binding rubber with metal or plastic.

### Features

- Offers superior adhesive strength without treating the surface with a primer, etc.
- Offers excellent adhesion to various types of rubber including chloroprene, EPT and natural rubber.

Note: Does not adhere well to some types of rubber. Test before attempting to put to practical use.

### Applications

- Fixing of rubber dams
- For vulcanized rubber cushions
- Temporary fixing or bonding of packing materials
- Fixing of cushioning such as rubber plates or foam; fixing of rubber legs

### Standard Size

Tape Thickness (mm)	Width (mm)	Length (m)
0.15	3-1,200	50

### Structure

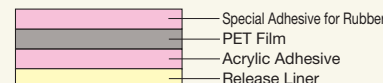

### Properties

#### Rubber Surface Treatment Method and 180° Peeling Force

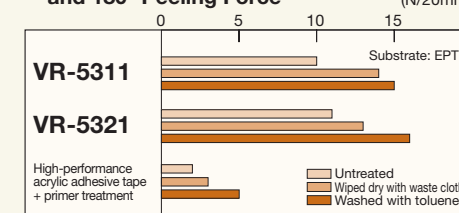

#### 180° Peeling Force for Each Type of Rubber

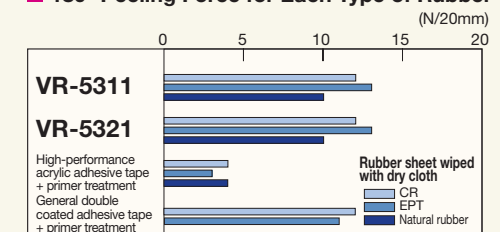

\*Measured by peeling in a 180° direction at a speed of 300mm/min at 23°C with polyester film 0.025mm lining.

## 14 Strong-adhesion and Repulsion Resistance Double-coated Adhesive Tape VR-5000/VR-5300/VR-5300H



**VR-5000/VR-5300/VR-5300H series products also conform well to curved surfaces.**

These double-coated adhesive tapes use a special rubber adhesive and exhibit excellent adhesion to many different substrates. These tapes can be widely used to bond curved surfaces of metal or plastic substrates and for fixing foam or rubber materials.

### Features

- Neither lifting nor peeling-off for curved surfaces.
- Used for every substrate.

### Applications

- For super-strong fixation of parts and components
- For fixing items to curved surfaces or resilient parts

### Structure

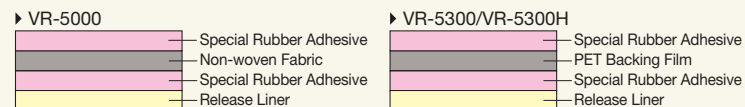

### Standard Size

Tape Thickness (mm)	Width (mm)	Length (m)
0.14	5-1,200	50

### Properties

#### 180° Peel Adhesion Test Results by Substrate Type



# 15 PO (Polyolefin) SPV™: Overview

**PO SPV™ is an environment-friendly surface protective material, which does not contain chlorine or plasticizer. The PO SPV™ product line-up offers many variations suitable for all sorts of applications.**

The following is the line-up of polyolefin SPV products, which all use special polyolefin film for their base. The numerous variations of PO SPV products are intended to meet various surface protection needs. Each product is made to be effective according to the nature of the surface protection, whether the surface is a metal sheet or plastic sheet, or whether the coated surfaces are to be protected during transportation or processing.

Product Group	Product No.	Thickness (mm)	Max. Width (mm)	Standard Length (m)	Color		
					White	Transparent	Blue (translucent)
M Series	M-6030	0.060	1,250	200	-	○	○
A Series	A-6050	0.065	1,250	100	-	○	○
C Series	C-6010	0.060	1,250	100	-	○	○
	C-100	0.060	1,250	200	-	○	-
	C-200	0.060	1,250	200	-	○	○
	C-300	0.060	1,250	200	-	○	○
	C-400	0.060	1,250	200	-	○	-
	C-500	0.060	1,250	200	-	○	-
	C-600	0.090	1,250	200	-	○	-
V Series	V-420	0.055	1,250	200	-	○	-
364 type	364CK2	0.050	1,250	100	-	○	-
	364MK2	0.055	1,250	200	-	○	-
	364FK2	0.043	1,250	200	-	○	-
	3643FK2	0.045	1,250	200	-	○	-

Substrates: stainless steel BA plate, acrylic plate

- As small lot production may be required depending on the size and the color of the product, please consult our sales representative.
- The above chart shows example of measured values, not guaranteed values.



## Surface Protective Materials Protection Film for Interior Parts SPV™-C-600

### Used for protection of automobile interior parts

SPV-C-600 has been developed for protecting automobile interior parts, which are exposed to severe heat and UV radiation. This film can be perfectly applied to suit any specific location and surface size for protection, as well as effectively prevents scratching and keeps the vehicles from getting dirty during the assembly process.

#### Features

- Can be used for interior parts with a wide choice of substrates; no adhesive residue remains when peeled.
- Adheres well to rough surfaces.

#### Structure



#### Standard Size

Product No.	Thickness (mm)	Width (mm)	Length (m)	Color
C-600	0.090	1,250	200	Transparent

#### Applications

- General interior parts such as door trim, instrument panels and door steps



# 16 Tape for Wire Harnesses Low-VOC PVC Tape/Heat and flame resistant, high heat resistant, thick type PVC adhesive tape



## PVC tape featuring Low-VOC, thin layer, heat-resistance and flame-retardant

This tape was developed to protect and bundle the wire harness (electric wire) which run all over automobiles. We are aiming to reduce vehicle's weight by making the tapes thinner as much as possible, and reducing the VOC level which also contributes to a better environment. Heat-resistant and flame-retardant tapes are also used in EV/HEV vehicle's wire harness.

#### Features

##### Low-VOC PVC Adhesive Tapes

- Flame-retardant tapes, heat-resistant tapes and other various products are available for many harnessing purposes.
- Environment-friendly tape of low VOC.
- General binding tape also has a thin layer type of 0.070mm thickness

##### Heat-resistance, flame-retardant and High heat-resistant PVC adhesive tape

- Flame-retardant tape also has a thin layer type of 0.070mm thickness
- Offers each temperature zone of heat-resistant type

#### Structure

##### Low-VOC PVC Adhesive Tapes

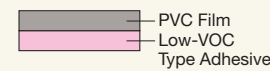

#### Applications

- For banding wire harnesses, identification and joint protection

#### Properties

##### Comparison of Base Properties

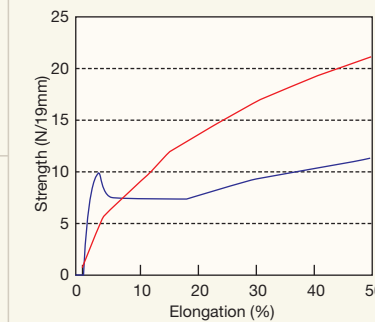

##### Comparison of the Characteristics of PVC Adhesive Tapes

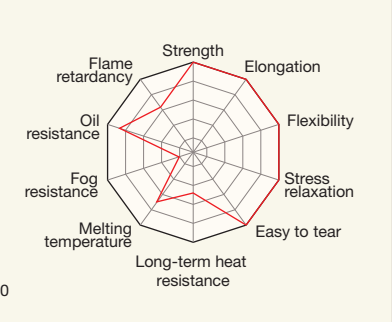

#### Low-VOC PVC Adhesive Tapes

Product	Product No.	Color	Thickness (mm)	Length (m)	Applications
General/bundling	No. 2117TVH/No. 2117NVH	Black	0.070	35	General unity thin layer type, Low VOC emission product
General	No.2100STVH/No.2100NVH	Black	0.13	20	General unity type, Low VOC emission product
Color variation	No. 2107TVH/No. 2107NVH	Black, Blue, Green, Yellow, White, Brown, Gray, Red, Orange, Pink, Light green, Sky blue, Purple, Transparent	0.13	20	Low VOC emissions, color identification use
Heat-resistant, flame-retardant	No.2237FRTVH	Orange, Gray	0.13	20	High Voltage Harness binding
	No.2238FRTV	Dark gray	0.09	30	Low Voltage Harness binding
High heat resistance	No. 2207TVH	Black, White, Orange	0.13	20	Heat-resistance temperature limit: 85°C
	No. 2280TV		0.08	33	Heat-resistance temperature limit: 105°C
	No. 2290TV	Black (Please inquire for other colors)	0.11	33	Heat-resistance temperature limit: 125°C
Harness Protection	No.212JTVH	Dark blue	0.25	12	Tube replacement use
	No.211TVH		0.20	15	Tube and sheet replacement use
Insulation & heat-resistant	No.223SH	Black, Blue, Green, Yellow, White, Gray, Red	0.190	20	Electronic insulation type

\*Symbols at the end of the product names: TV=Made in Taiwan NV=Made in China

# 17 Acetate Cloth Adhesive Tape Series

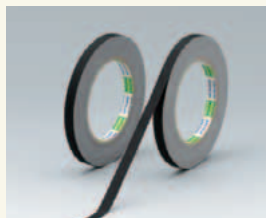

Acetate cloth adhesive tape offers superior heat resistance and flexibility.

Electrical insulation tape consists of acetate cloth coated with acrylic or rubber adhesive. These tapes are used for insulating electrical and electronic equipment, protective insulation of wire harnesses and binding.

### Features

- Easy to work with good hand-cuttability
- Superior flexibility makes it ideal for binding uneven electrical wiring.
- Offers superior corrosion resistance.
- Environment-friendly tape of low VOC (No. 5EG, No. 153, No. 153N)
- High adhesion to backing and any adherend (No. 153, No. 153N)
- No.153N is a flame-retardant version of No.153.

### Applications

- Outer insulation and termination of coils.
- For binding connection harness
- For binding airbags (No.153/No.153N)

### Structure

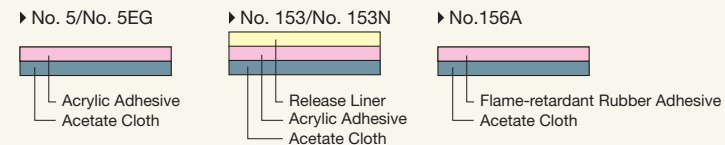

### Properties

Product No.	Thickness (mm)	Standard Length (m)	Color	Peeling Force (N/19mm)	Tensile Strength (N/19mm)	Elongation (%)
No. 5	0.23	20/30/50	White/Black	5.0	120	20
No. 5EG	0.23	20/50	Black	6.0	120	20
No.153	0.21	50	White/Black	10.0	120	20
No.153N	0.21	50	White	8.0	100	20
No.156A	0.25	30	White/Black	8.0	130	20

No.156A (UL 510 Flame Retardant E34833)

# 19 Super Clean Foam SCF™ 100-200-400/P1500



Can handle microscopic clearances of 100µm. Thin layer, flexible and highly workable foam

SCF is a highly flexible foam, which has a fine cell structure with a thinner and stronger layer than conventional foam, used for cushioning and dustproofing. A superior ability to follow contours enables SCF to be used for clearances as small as 100µm. Its higher dustproofing reliability realizes more freedom of design. SCF offers flexibility while facilitating work.

### Features

- Superior compression and mounting properties enable foam to fit in tiny clearances.
- Superior ability to follow curves and uneven shapes enables the foam to be used for complicated designs.
- Enables fine width and thin layer processing, hence, the foam is applicable to complicated shapes.
- Easy to work with; can be used with no backup or thin backup.
- High impact absorption helps protecting LCDs.
- Clean; minimizes contamination to LCDs and other parts.

### Product Line-up

Product No.	Thickness (mm)	Color	Length (m)	Width (mm)
SCF™100	0.5-1.0	Black	1-100	500
SCF™200	0.5-1.5			
SCF™400	0.3 / 0.4			
P1500	0.4-1.5			

\*Tape thickness is available in 0.1mm. Double-coated adhesive tape is also available.

### Applications

- Sealing materials for car navigator monitor frame
- Sealing materials for ETC receiver



# 18 Waterproof Insulation Sealing Material NF Series

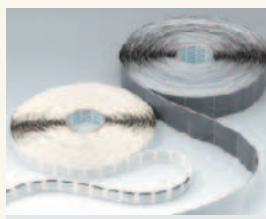

This material uses a non-halogen, flame retardant, lead-free compound in consideration of the environment.

We are expanding the applications of this sealing material to automobiles based on its record of achievement and reliability as an insulating material and filling and sealing material for branches, and other parts, of overhead power wires. Products that conform to various applications and methods of use are available.

### Features

- Exhibits excellent adhesion to rough surfaces and electric wires (including non-halogen wires).
- Uses a non-halogen, flame-retardant compound and has low temperature to high temperature flexibility.
- PVC backing (NF-500PV) is lead-free in consideration of the environment.
- Does not droop at high temperature.
- Excellent electrical properties.

### Properties

Item	Unit, test method	NF-500
Flame retardancy	15-second flame test	Self-extinguishment, No dripping matter
	Continuous 2-minute flame test	No dripping matter
Oxygen index	-	30
Adhesion	N/20mm	63.6
50% compression load*1	N/cm <sup>2</sup>	11.5
Volumetric resistivity	Ω·cm	6.6 x 10 <sup>14</sup>
Withstand voltage	5 kV 1 min.	No abnormality
Dielectric breakdown voltage	kV/mm	24
Droop test*2	1 mm max.	0
Hue	-	Black

\*1 20 mm x 20 mm, compression ratio 5 mm/min.  
\*2 Drooping distance over 24 hours at 100°C

### Structure

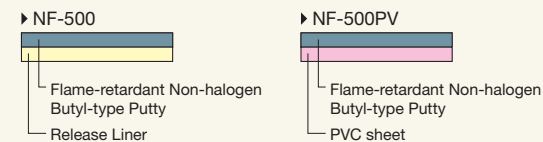

### Properties

Product No.	Density (g/cm <sup>3</sup> )	50% Compression Load (N/cm <sup>2</sup> )	Tensile Strength (N/cm <sup>2</sup> )	Extension (%)	Flame Retardancy
SCF™100	0.045	1.4	1.00	210	-
SCF™200	0.030	2.4	0.93	167	-
SCF™400	0.045	1.4	1.09	141	-
P1500	0.070	4.6	0.70	60	UL94HF1 (Non-halogen)

### Structure

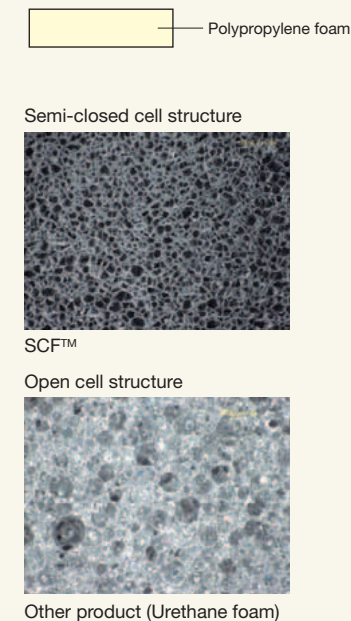

### Flexibility

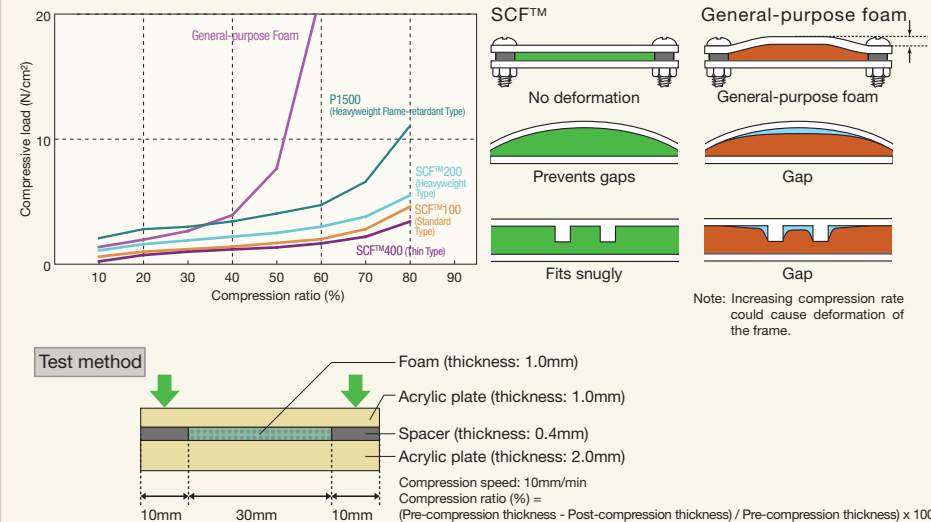

### Low VOC\* Double-coated Adhesive Tape No. 512



#### Reduces the amount of VOC emissions.

No. 512 features a solvent-free acrylic adhesive and has less odor and VOC diffusion amount. No. 512 emphasizes "adhesion" and "easy handling" and adheres well to a wide range of substrates, including rubber foam and plastic materials. Awarded the 46th "Environmental Award" in Japan.

\*VOC: Volatile Organic Compounds

#### Features

- Odor is drastically reduced compared to the existing line-up.
- VOC diffusion amounts are extremely small.
- Outstanding adhesion to PP, PE, etc.
- Tape is flexible and has superior adhesion to rough surfaces.
- Superior initial adhesion.

#### Structure

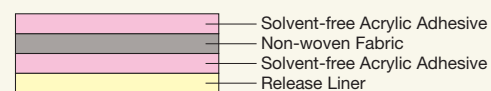

#### Standard Size

Thickness (mm)	Width (mm)	Length (m)
0.15	3-1,200	20/50

#### Applications

- Fixing various types of nameplates
- Fixing plastic displays
- General adhesion (adhesion of paper, film, etc.)



Fixing sound absorption materials around instrument panels



Fixing door trim and sound absorption materials



Fixing toner covers



Fixing floor mats

#### Properties

##### 180° Peeling Force (by Temperature)

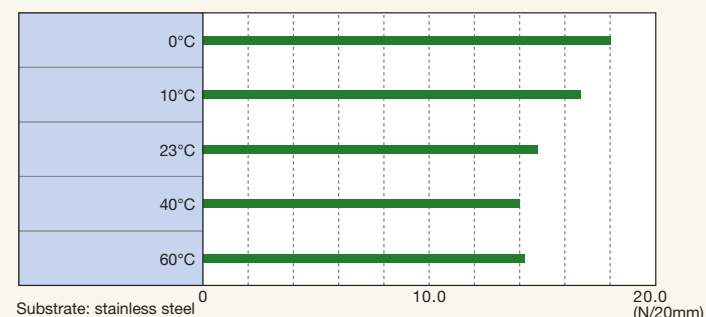

##### 180° Peeling Force (by Substrate)

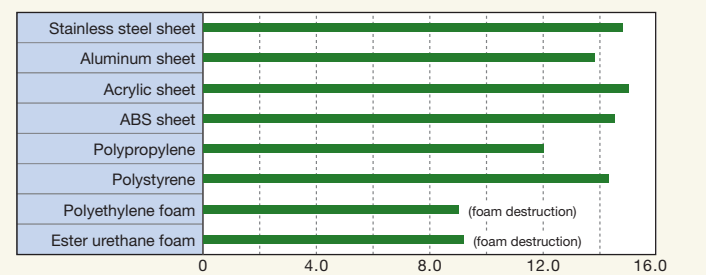

\*Measured by peeling in a 180° direction at a speed of 300mm/min at 23°C with polyester film 0.025mm lining.

##### No. 512 Measurements of VOC Diffusion and Speed

Measured Substances	MHLW*2 Guidelines (µg/m³)	Densities (µg/m³)	Diffusion Speed (µg/m²·h)
Formaldehyde	100	<5	<1
Acetaldehyde	48	<5	<1
Toluene	260	<5	<1
(o, m, p-) Xylene	870	<5	<1
Ethylbenzene	3800	<5	<1
Styrene	220	<5	<1
Tetradecan	330	<5	<1
Di (2-ethylhexyl) phthalate	120	<0.5	<0.2
Di-n-butyl phthalate	220	<0.5	<0.2

\*1 Method of analysis: VOC analysis implemented by small-chamber method in compliance with JIS A 1901.

\*2 The measured values of VOC diffusion, stated above, are less than the guideline values of the Ministry of Health, Labour and Welfare of Japan.

### Removable Tape No. 5000NS

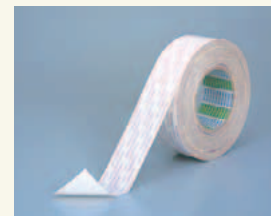

#### Flexible and strong nonwoven fabric carrier for easy removal

No. 5000NS is a double-coated adhesive tape, which consists of a strong and flexible nonwoven fabric carrier and powerful, pressure-sensitive adhesive. No. 5000NS can be adhered to various types of substrate, such as metal, plastic and urethane foam; at the same time, its superior tensile strength makes for easy removal without tearing. Nitto has resolved the problem of adhesive residue. Special adhesive is used for No. 5000NS, and this minimizes the residue of the adhesive when the tape is peeled off. All of these properties facilitate recycling; tape is removed easily for the parts to be disassembled, while adhesive residue is minimal and allows the parts to be reused.

#### Features

- Can be used for substrates to which it is usually difficult to apply tape, such as polyacetal and polypropylene.
- Non-woven fabric base offers excellent peeling properties; tape does not tear when peeled.
- Minimal adhesive residue when removed, even when it is removed after a long period of time.
- Can be used in a wide range of temperatures.

#### Structure

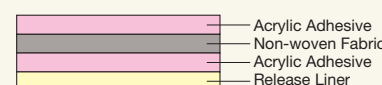

#### Standard Size

Carrier	Tape Thickness (mm)	Width (mm)	Length (m)
Non-woven Fabric	0.16	3-1,200	50

#### Properties

##### Tensile Strength

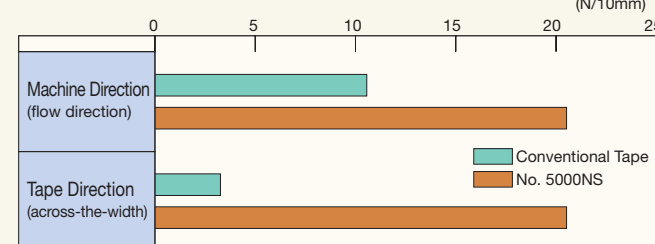

##### Test Method

Specimen size: 10mm (cut in machine direction and tape direction)  
 Measurement temperature: Room temperature  
 Peeling speed: 100mm/min.  
 Distance between chucks of tensile tester: 50mm

##### 180° Peeling Force (by Substrate)

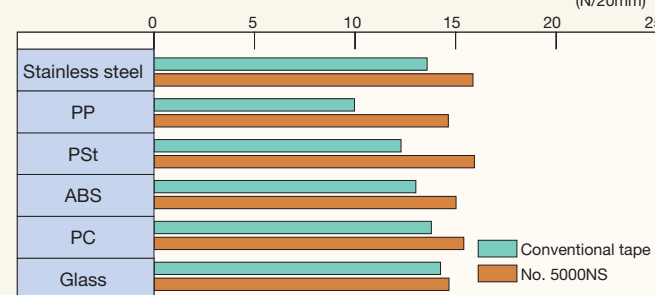

\*Measured by peeling in a 180° direction at a speed of 300mm/min at 23°C with polyester film 0.025mm lining.

#### Applications

- Adhesion of PP and foam objects
- Fixing of various types of nameplates

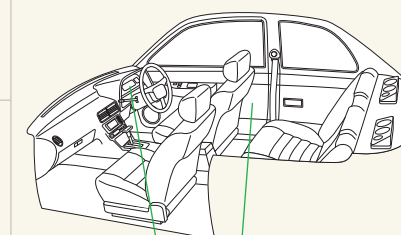

#### Example: Toner Cartridge Recycling

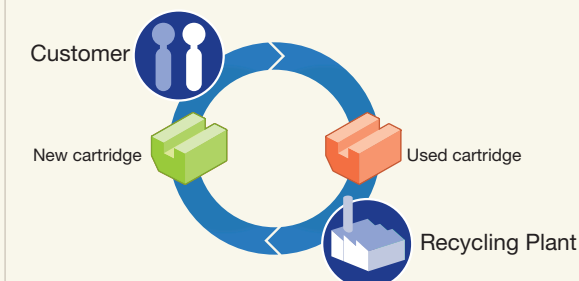

##### Disassembly

The tape is removed without tearing and leaves minimal adhesive residue, enabling effective parts disassembly. Facilitates recycling and can be reused either as processed or raw materials.

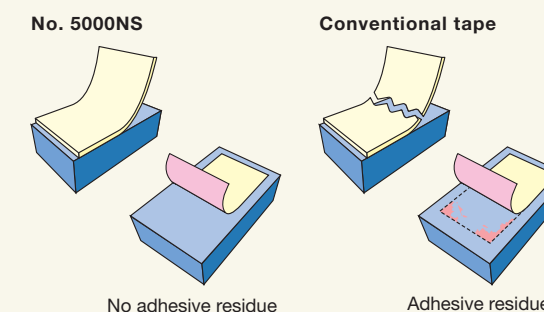

### Double-coated Adhesive Tape for Oily Surface OW-5016



**This environment-friendly low-VOC\* adhesive tape also sticks well to oily surfaces.**

This adhesive tape uses a solvent-free adhesive agent, resulting in low VOC emission levels. The 14 VOCs specified by the Ministry of Health, Labour and Welfare are not used in the adhesive tape as raw materials. This tape is suitable for fixing a wide variety of substrates such as metals, plastics, and foams. In addition, it has the potential to be used on oily surface. Awarded the 46th "Environmental Award" in Japan.

\*VOC: Volatile Organic Compound

#### Features

- Excels in adherence to oily surface.
- Organic solvents are not present in the adhesive agents.

#### Structure



#### Standard Size

Tape Thickness (mm)	Width (mm)	Length (m)
0.16	3-1,050	20/50

#### Applications

- General seat frame
- Seat back frame
- Seat cushion



#### Properties

##### Adhesion to Many Different Oils

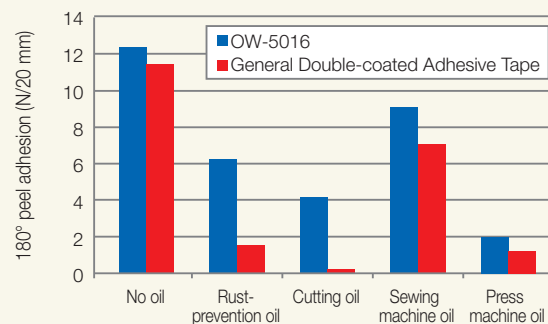

\* Substrate: SUS304BA Oil spread: 5 g/m<sup>2</sup>  
Measurement: 30 minutes after bonding

##### 180° Peel Adhesion-by Oil Surface and by Pressure Bonding Time

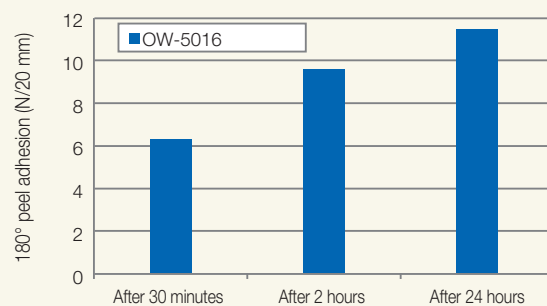

### Low-VOC\* Double-coated Adhesive Tape EW-514/EW-514D/EW-514DB



**Environment-friendly and suitable to adhesive for rough surface**

Double-coated adhesive tape exhibits minimum amount of VOC discharge level with the use of solvent-free acrylic adhesive. And superior repulsion resistance. Awarded the 46th "Environmental Award" in Japan.

\*VOC: Volatile Organic Compound

#### Features

- Use no organic solvents (toluene, xylene, ethyl acetate, etc.)
- The guideline values for the 13 VOCs specified by Japan's Ministry of Health, Labour and Welfare are satisfied.
- Excellent adhesion to rough surface (foam, non-woven fabric, felt).
- EW-514D/EW-514DB are good performance for rough surface because of its thickness.

#### Structure

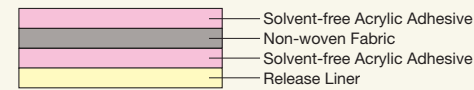

#### Applications

- Fixing of sound-absorption materials for automobile interior parts and home electrical appliances.
- Bonding of film and paper.
- Fixing of various plastics.

#### Standard Size

Product No.	Thickness (mm)	Width (mm)	Length (m)
EW-514	0.14	5-1,050	50
EW-514D EW-514DB	0.28	10-1,050	50

#### Properties

##### 180° Peeling Force According to Type of Substrate

Product No.	Peeling Force (N/25mm)		
	Stainless	Ether Type Urethane Foam	Ester Type Urethane Foam
EW-514	12.0	2.8	11.0
EW-514D EW-514DB	14.0	9.0	16.0

\*Measured by peeling in a 180° direction at a speed of 300mm/min at 23°C with 0.025mm PET lining.

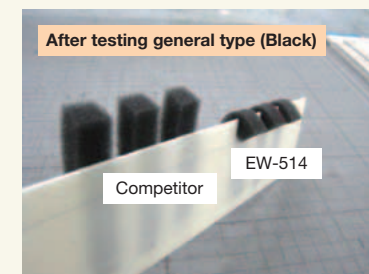

##### Repulsion Resistance (For Urethane Foam)

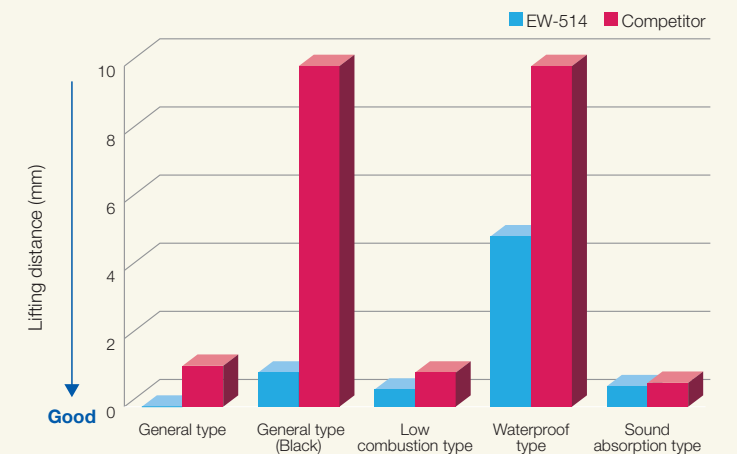

##### Test Measurement

Foam thickness: 10mm  
 Foam or tape width: 10mm  
 Fold length: 10mm  
 Method of pressing: Foam and tape...Only self-weight  
 Tape with foam and substrate (ABS)...  
 2kg roller is applied in one back-and-forth motion  
 Measure condition: 23°C/50%×24hrs.+70°C×2hrs later, measure lifting distance.

24

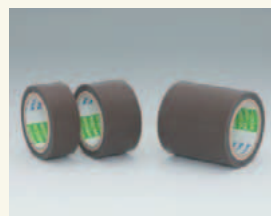
Fluoroplastic Adhesive Tape NITOFLO<sup>TM</sup> No. 903UL

**Fluoroplastic (PTFE) adhesive tape with excellent heat resistance, insulation, sliding.**

Adhesive tape with silicone adhesive applied to fluoroplastic (PTFE) film. Can be used in a temperature range of -60°C to 200°C and meets UL-510 flame retardant standards. Excellent electrical insulation and sliding property. Can be used in a variety of applications utilizing the features of fluoroplastic.

## Applications

- Sliding noise abatement
- Heat-resistant electrical insulation

## Standard Size

Product No.	Thickness (mm)	Maximum Width (mm)	Standard Length (m)	Color
No. 903UL	0.08/0.13/0.18/0.23	450	10	Gray

## Structure

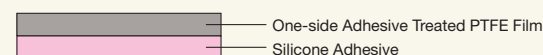

## Properties

Product No.	Peeling Force (N/19mm)	Tensile Strength (N/19mm)	Breakdown Voltage (kV)	Elongation (%)
No. 903UL	7.1	93	11	220

Thickness: 0.13mm

26

## Glass-cloth Adhesive Tape No.188UL

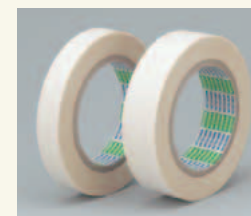

**Glass-cloth adhesive tape offers superior strength and heat resistance.**

With class H heat resistance and mechanical strength (UL-certified), No.188UL consists of glass cloth coated with pressure-sensitive silicone adhesive. In addition to holding and bundling of electrical wiring, No.188UL is also ideal as a heat-resistant masking tape.

## Features

- Offers superior physical strength and electrical insulation properties.
- Offers superior thermal insulation.

## Structure



## Standard Size and Properties

Product No.	Thickness (mm) Total (Backing)	Standard Length (m)	Color	Peeling Force (N/19mm)	Tensile Strength (N/19mm)	Elongation (%)	Breakdown Voltage (kV)	Electrolytic Corrosion Factor
No.188UL	0.180 (0.130)	33	White	6.7	600	5	3.5	0.96

25

Fluoroplastic Resin Impregnated Glass Cloth Adhesive Tape NITOFLO<sup>TM</sup> No. 973UL-S

**Excellent heat resistance, releasing property and mechanical strength. Contribution to the heat-resistant releasing of heat sealing equipments.**

Glass cloth base material impregnated with polytetrafluoroethylene (PTFE) dispersion then sintered. Single surface treated and coated with a silicone adhesive, which exhibits excellent heat resistance and mechanical strength.

## Applications

- Heat-resistant fixing
- Smooth sliding

## Standard Size

Product No.	Thickness (mm)	Length (m)	Color
No.973UL-S	0.13	10	Beige

## Structure

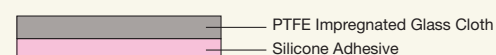

## Properties

Product No.	Peeling Force (N/19mm)	Tensile Strength (N/19mm)
No. 973UL-S	6.8	240

27

## Polyimide Adhesive Tape No. 360 Series



**Widely used for heat-resistant electrical insulation of electrical electronic equipments.**

Tape with polyimide film backing with superior heat resistance. Widely used in a variety of applications, such as the insulation of electrodes in lithium ion secondary batteries and applications requiring heat resistant masking, such as in component mounting reflow processes and the manufacturing processes of various types of electronic components.

## Applications

- Heat-resistant masking
- Heat-resistant electrical insulation

## Standard Size

Product No.	Thickness (mm)		Length (m)	Color
	Backing	Total		
No. 360UL	0.025	0.060	20	Light amber brown
	0.050	0.090		
No. 360A	0.025	0.053	20	
	0.050	0.080		

## Structure

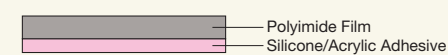

## Properties

Product No.	Peeling Force (N/19mm)	Tensile Strength (N/19mm)	Elongation (%)	Breakdown Voltage (kV)	Electrolytic Corrosion Factor
No. 360UL	5.4	145	65	8.0	1.00
	5.4	250	65	11.0	
No. 360A	4.0	145	65	8.0	1.00
	4.4	250	65	11.0	

### High Performance Vent Filter TEMISH™



**Allows clean air to come in, but keeps out water and dust.**

TEMISH is PTFE (Polytetrafluoroethylene) porous membrane developed by Nitto. With hundreds of millions of micropores/cm<sup>2</sup>, TEMISH features water-resistance, dustproofing and air permeability. It also exhibits water, heat, chemical and weather resistance as well as exhibiting electrical properties, as excellent attributes of PTFE resin.

#### Structure

**Water resistance**

TEMISH has a 0.1µm to 10µm porous membrane, therefore it has excellent water-resistance against 100µm to 300µm of water droplets/rain.

**Air permeability**

TEMISH allows 0.0004µm of water vapor to pass through 0.1µm to 10µm of porous membrane.

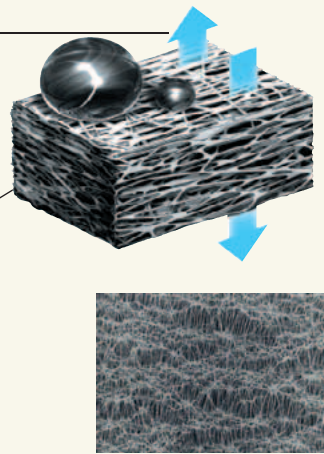

#### Function

##### Selective Permeability Filter Function

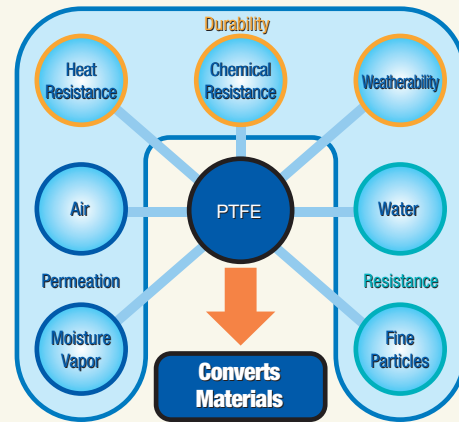

### Evaluation Methods for TEMISH™

#### Air Permeability Test (Gurley Method) [JIS L 1096]

Measurement area: 642mm<sup>2</sup>  
Measurement air volume: 100ml  
Measurement pressure: 1.23kPa

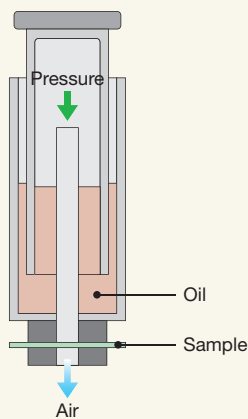

#### Air Permeability Test (Frazier Method) [JIS L 1096]

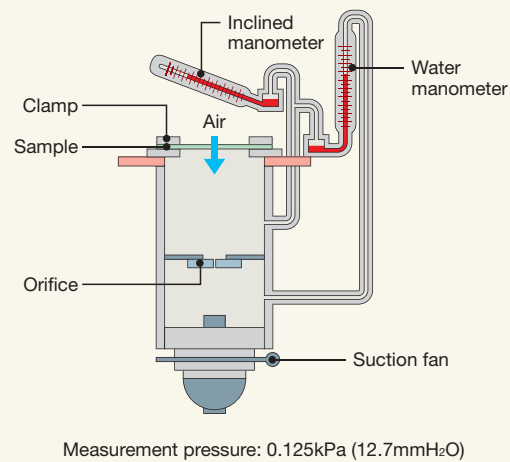

#### Water Resistance Test [JIS L 1092]

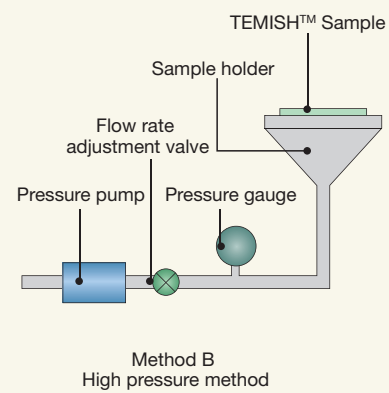

### Applications

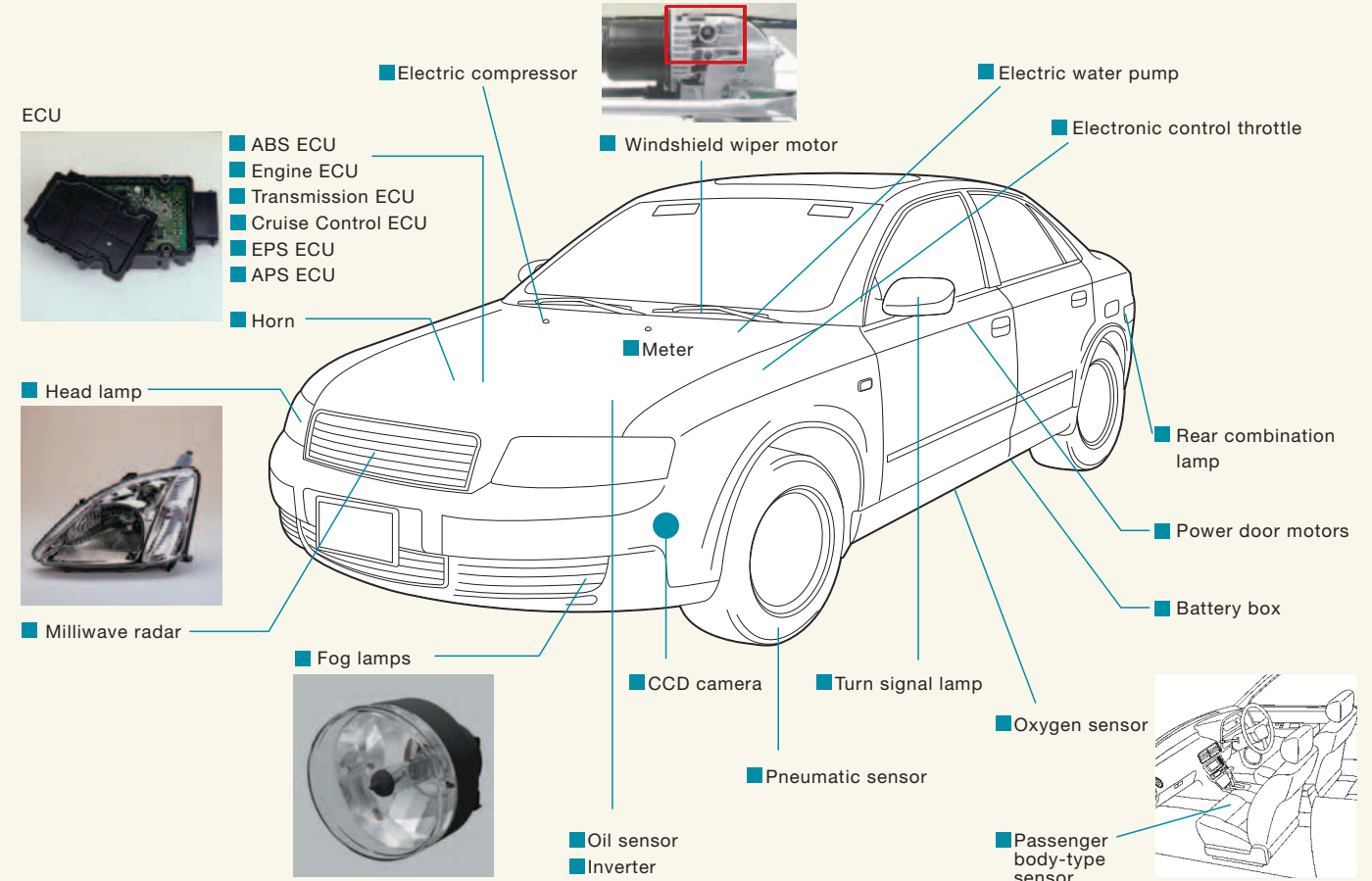

### Product Line-up (Patch Type)

Type	Backing Materials	Product No.	Thickness (mm)	Air Permeability*1		Water Resistance*2 (kPa)	Applications
				Gurley (sec)	Frazier (cm <sup>3</sup> /cm <sup>2</sup> -sec)		
Two-layered product Hydrophobic type	PET net	S-NTF1026-N07	0.07	7	-	200	High water resistance
		S-NTF1033-N07	0.07	(0.3)	5	7*3	High air permeability
Two-layered product Oleophobic type	PET net	S-NTF2026A-N07	0.07	13	-	200	Oleophobic, high water resistance
	Printed PET non-woven fabric	S-NTF2131A-PS06	0.20	12	-	100	Oleophobic, high water resistance, high strength, high heat resistance
	PET non-woven fabric	S-NTF2122A-S06	0.20	35	-	250	Oleophobic, high strength, high heat resistance
		S-NTF2131A-S06	0.20	12	-	100	
Single-layered product Oleophobic type	-	S-NTF2133A-S06	0.20	4	-	30	Oleophobic, high water resistance, no difference between front and back sides, Ultra high heat resistance
		S-NTF820A	0.30	14	-	100	

\*1 Gurley testing method, Frazier testing method \*2 B Method (high water pressure) \*3 A Method (Low water pressure)

## Features of Oleophobic TEMISH™

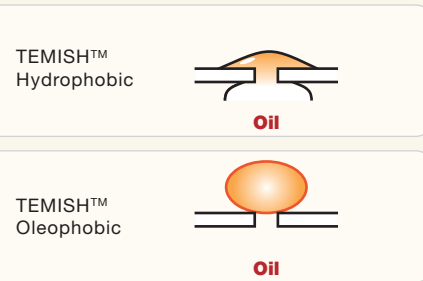

Test Fluid	25°C		
	5 min.	48 hrs.	96 hrs.
Engine oil	○	○	○
Long life coolant	○	○	○
Battery fluid	○	○	○
Washer fluid	○	○	○
Neutral detergent	○	○	○
Brake fluid	○	○	○
Grease	○	○	○
Saturated calcium chloride solution	○	○	○

[ Test method ]  
Drop-test liquid on TEMISH PTFE porous membrane and check if the liquid penetrates at room temperature (25°C).  
○ indicates that the liquid did not penetrate. × indicates that the liquid did penetrate.

## Patch Type

### Composition of Product

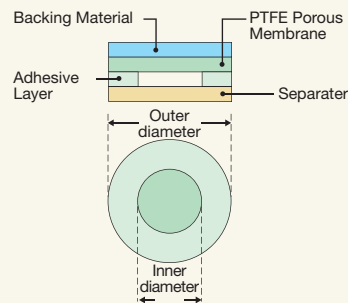

### Sheet

Outer diameter	Sample size (mm)														
	4.8	5.6	7	10	11	12	14	16	18	20	23.5	25	30	35	40
Inner diameter	2.3	3	4	6	—	5	8	10	12	15	17.5	20	25	30	35

### Reel

Outer diameter	Sample size (mm)								
	7	8	12	13.8	14	15	16	16	28
Inner diameter	4	4	5	6	6	7	10	12	18

\* General processing tolerance ±0.2mm  
\* Please consult our sales representative for other available sizes.

### Sheet

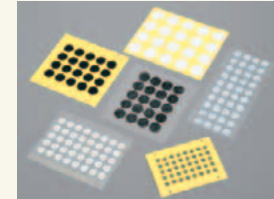

### Reel

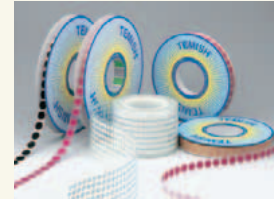

### Explanation of Product No.

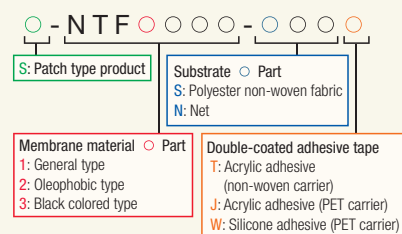

### Precautions for handling and processing TEMISH™

- Do not damage surface.
- Do not load on the membrane package.
- Do not use pointed tweezers to pick up the membrane.
- Do not apply undue tension or pressure on the product or expose to excessive heat, friction or ultrasonic waves.
- Remove static electricity from the membrane because it charges easily and may be damaged by the charge.
- Avoid dust and attaching packaging paper when storing.
- Store indoors at room temperature, away from direct sunlight.
- Avoid oil, soap and oils from skin from touching the product.
- Do not burn fluoroplastic products.
  - Poisonous gas is produced if processed product chips or used product is burned. Please dispose of it in a landfill.

## TEMISH™ VPF Series

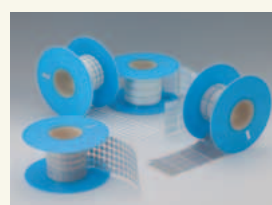

### Features

- The filter design is specific for automotive lamps to quickly discharge pressure and moisture in the lamp.
- Excellent properties such as waterproofing, dust-proofing, and oil-repellent.

Mass production (reel form only)

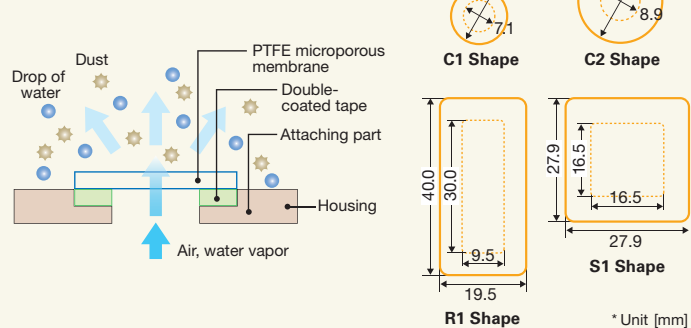

Product No.	Features	Typical applications	Air permeability*1 (cm <sup>3</sup> /min)		Water entry pressure*2 (kPa)	
			Typical value	Minimum value	Typical value	Minimum value
VPF110A2-R1	PTFE Single-layered product	LED Head Lamp / Rear Lamp	215	> 105	100	> 70
VPF110A2-S1			205	> 100	100	> 70
VPF110A2-C1		LED Rear Lamp / Fog Lamp	30	> 15	100	> 70
VPF110A2-C2	45		> 24	100	> 70	
VPF310A2-R1	High ventilation three-layers product	LED Head Lamp / Rear Lamp	2200	> 860	50	> 15
VPF310A2-S1			2100	> 825	50	> 15
VPF310A2-C1		LED Rear Lamp	300	> 130	50	> 15
VPF310A2-C2			470	> 190	50	> 15

\*1 Permeation volume at differential pressure 1kPa  
\*2 JIS L 1092 B method (high water pressure method)  
\* This data is a representing value, not guaranteed performance.  
\* It is a special product for the automotive lamp vent filter applications. Please refrain from using it for other uses.

## TEMISH™ Composite Parts

- New functions have been exhibited by compounding TEMISH with molded objects, such as plastic and rubber, and making components.
- Compounded parts realize total cost reduction by reducing the numbers of components and man hours for mounting.

## TEMISH™ CAPSEAL™

### Structure

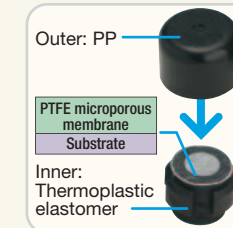

### Functions of Cap Seal

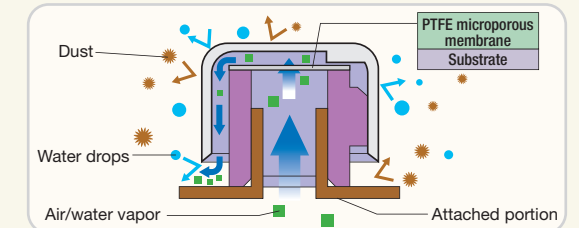

### Features

- As cap seal has been made into a component, it enables one-step attaching, and reduces total costs.
- Offers superior mechanical strengthening and is easy to use.
- The filter is protected by a cap and thus prevents direct damage to the membrane surface.

Product No.	Features	Main Applications	Color (outer)	Air Permeability (cm <sup>3</sup> /min)	Water Resistance (kPa)
C2-NTF1026-L01	High water resistance	Fog lamps, rear lamps	Black	50*1	100*3
C2-NTF9208-L01	High air permeability	Head lamps, rear lamps	Gray	1,500*1	20*3
C2-NTF130SL	High air permeability	Head lamps	Brown	13,000*1	3*2
C2-NTF210SL	Oleophobic, high water resistance	Fog lamps	Blue	50*1	100*3
C2-NTF220SL	Oleophobic, high air permeability	Head lamps, rear lamps	Green	1,500*1	20*3

\*1 Volume of air permeability when the differential pressure is 1kPa. \*2 JIS L 1092 A method (low water pressure method) \*3 JIS L 1092 B method (high water pressure method)

## TEMISH™ Z Series

### Structure

Z3-NTF210SE



Z-PLUG-S



### Cross Section

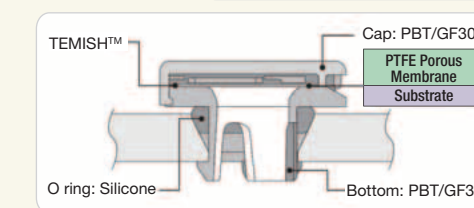
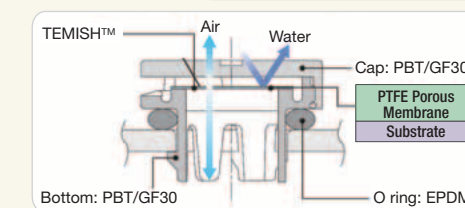

### Features

- Has excellent oil repellency and restricts various types of automobile-related oils.
- Has superior durability and is suitable for internal pressure adjustment materials for automobile ECU.
- Enables one-step attachment in the desired direction.
- High-heat and low-temperature resistance. (-40°C to 125°C)

Product No.	Features	Main Applications	Color (outer)	Air Permeability (cm <sup>3</sup> /min)	Water Resistance (kPa)	Waterproof Standard
Z3-NTF210SE	Oleophobic · high water resistance	ECU, Battery pack	Black	130*1	210*2	—
Z-PLUG-S				260*1	100*2	High water pressure resistant test [IPX9K]
ZH-PLUG-S				500*1	60*2	
ZH2-PLUG-S						

\*1 Volume of air permeability when the differential pressure is 1kPa. \*2 JIS L 1092 B method (high water pressure method)

## TEMISH™ E3-NTF Series

### Structure

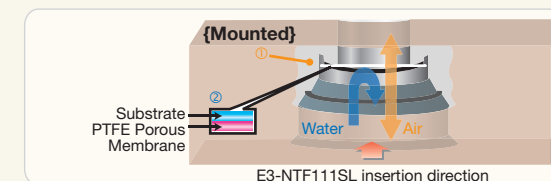

### Features

- Can be mounted in "one-touch". (Recommended to mount with non-woven fabric side [black] up.)
- Excellent air permeability, water resistance, and dustproofing properties.

### Features

Product No.	Features	Main Applications	Color (outer)	Air Permeability (cm <sup>3</sup> /min)	Water Resistance (kPa)
E3-NTF111SL	High water resistance	Motor	Black	23*1	100*2
E3-NTF211SL	Oleophobic	Motor	Black	20*1	100*2

\*1 Volume of air permeability when the differential pressure is 1kPa. \*2 JIS L 1092 B method (high water pressure method)

### HT Sheet with High Thermal Conductivity

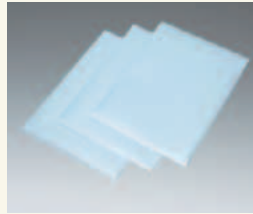

The HT series with high thermal conductivity is utilized in various fields, including in-vehicle components centered on digital electrical appliances. Thin film formation will be utilized as a tape manufacturer to address customer needs based on the heat radiation and insulation design that is accumulated from aluminum-based heat-radiating substrate.

#### HT Series

Extra soft thermal-conductive sheet with the matrix resin of silicone gel

##### Structure

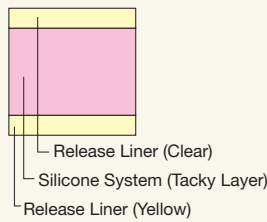

##### Functions

Test item	Unit	HT-050	HT-080	HT-100	Test method
Thickness	mm	0.5 ± 0.05	0.8 ± 0.1	1.00±0.1	Dial gage
Hardness	—	21			Asker A
Tensile strength	Mpa	0.70			ASTM D412
Elongation	%	158	164	150	
Breakdown voltage	kV	6	8	11	ASTM D149
Thermal conductivity	W/mk	1.0			ASTM E1530
Thermal resistance	m <sup>2</sup> k/W	0.50x10 <sup>-3</sup>	0.82x10 <sup>-3</sup>	1.04x10 <sup>-3</sup>	

#### Application

##### Between MPU, package and heatsink, cooleruni

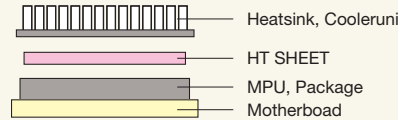

##### Between MPU, package and metal, housing

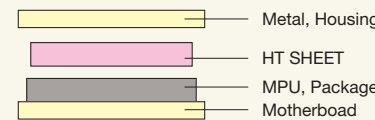

#### Notes

- Wipe off the oil, moisture and dust thoroughly on the surface on the adherend such as the heat sink, cooler unit, metal chassis, MPU and the package.
- To adhere well, press the adhesive hard against the adherend.
- Store this product in a cool dark place out of direct sunlight.
- Before use, make sure that the specifications of this product are suitable for the application.

### Heat-resistant Moisture Proof Coating Material for PCB ELEM COAT LSS Series



In addition to the fundamental features of flexibility, low moisture permeability, and hydrolysis resistance, the new moisture proof coating material offers the following features:

- 1) Heat resistance
  - 2) Use of solvents that conform to the PRTR and the Export Trade Control Order
- This new heat-resistant moisture proof coating product contributes to environmental load reduction.

#### Features

- Does not include solvents prohibited by PRTRs and overseas shipping regulations, reducing environmental loads.
- Low Young's modulus and coefficient of thermal expansion means the material is not affected by temperature changes, so there is no stress on boards or chips.
- Forms film only 5-10 minutes after coating. Also, uses a polymer consisting of a modified rubber-based material as its primary ingredient, so the film is resilient and resists the development of cracks.
- LSS-520MHF enables black-light smear tests to be performed. We have the diluted product which can be coated by curtain coating without dilution by customer. (K type)
- LSS-540E is VOC-free.

#### General Properties

Item	Unit	LSS-520MH	LSS-520MHB	LSS-520MHF	LSS-520MHB-K	LSS-520MHF-K	LSS-540E	Measuring Condition
Solid content	%	25	25	25	15	15	40	—
Viscosity	mPa · s	400	400	400	40	40	12	ASTM D-1084
Color	—	Clear	Blue	Fluorescence	Blue	Fluorescence	Milky white	—
Young's modulus	MPa	75	75	75	75	75	9.2	Tensile speed: 10mm/min.
Elongation	%	460	460	460	460	460	500	Tensile speed: 300mm/min.
Moisture permeability	g / cm <sup>2</sup> · day	0.002	0.002	0.002	0.002	0.002	0.0035	40°C X 90% Thickness: 100µm
Set time to touch	Min.	5	5	5	5	5	15	Thickness: 30µm
Thermal resistance	125°C	>5000	>5000	>5000	>5000	>5000	>2000	Time until elongation ratio reduce by half
	150°C	1200	1200	1200	1200	1200	>2000	

\* The above chart shows example of measured values, not guaranteed values.

### Insulating Paper NPN



Realization of multilayered structure by bonding multi-functional adhesive and by ad-hoc material selection

Providing insulating paper with excellent insulation, heat resistance, durability and mechanical strength for eco-car motor

#### Features

- Insulation
  - Ordinary temperature: 40°Cx90% RH24Hr
  - The distilled water soaking of 25°C in 24 hours: It preserves the insulation properties and breakdown voltage of the ordinary temperature
- Heat resistance
  - IEC international standards
  - Tensile strength F class (155°C)
  - Dielectric breakdown strength H class (180°C)
- Durability
  - Reliability and endurance based on the arrhenius plot and on the motor-let test
- Mechanical strength
  - Support for the automation of the motor manufacturing process
  - Insert performance in stator-slot
  - Strength properties are not bucked

#### Application

- Example of use in the motor
  - Slot paper
  - Wedge paper
  - Phase paper

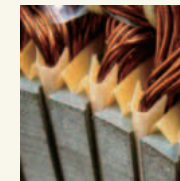

#### Properties

Product No.	Thickness (mm)	Tensile Strength (MD) MPa	Tensile Strength (TD) MPa	Dielectric Breakdown Voltage (kV)
NPN-252(SA)	0.29	105	100	20